

Application guide

CLEANAIR 23LX



- Providing indoor climate comfort



INTRODUCTION 2

RANGE

Air flow 3
 Dimensions 4

UNIT CASING

Frame and panels 5
 Base frame 6
 Roof 6
 Auxiliary section 6
 Handles, hinges inspection ports and lights 7
 Safety devices 7
 EN1886 classification 8
 Characteristics of the principal material used 9

DUCTING CONNECTIONS EXTRACT, EXPULSION, SUPPLY

Types 10
 Dampers 10
 Flexible connections 10
 Fresh air intakes 10

FILTERS

Types 11
 Medium efficiency pleated filters 11
 Medium efficiency bag filters 11
 Medium efficiency roll filters 11
 High efficiency bag filters 12
 High efficiency rigid bag filters 12
 Semi absolute filters 12
 Absolute filters 12
 Carbon filters 12
 Classification of filters 13
 Filter applications 14
 Quantity and dimensions of filter cells 15

COILS

Introduction 16
 Dimensions of water, direct expansion and steam coils 17
 Dimensions of electric coils 18

CONDENSATE DRAIN PANS – DROPLET ELIMINATORS

Drain pans 21
 Droplet eliminators 21

HUMIDIFIERS

Humidifiers with evaporating pack 22
 Steam humidifiers 23
 Atomized water humidifiers 24
 Air washers 25

ENERGY RECOVERY

Cross flow heat exchangers 26
 Heat wheels 27
 Run around coils 28
 Heat pipes 28

ATTENUATORS 29

EMPTY SECTIONS 29

FAN SECTIONS

Introduction 30
 Fans 31
 Motors 31
 Transmissions 31
 Antivibration mounts 32
 Fan diameter 33

DIMENSIONS

Dimensions of externally mounted dampers 35
 Typical length of the main components 36

Our company is member of the Eurovent certification program. The CLEANAIR Lennox air handling units are tested and rated in accordance with Eurovent certification program.



INTRODUCTION

The series 23LX airhandling units consist of modular sections which can be assembled to satisfy all forms of air treatment such as simple ventilation, filtration, heating, cooling, and control of humidity.

The 23LX series airhandling units are available in 44 sizes and cover an airflow range from 1000 to 80000 m³/h (0.278 to 22.222 m³/s) and with total pressures up to 2500 Pa. Special units can also be supplied for airflows and pressures outside the normal range. The wide range of unit sizes facilitates the best choice in relation to the requested face velocity.

The series has been developed and dimensioned in length, width and height, using a module of 160mm and has 28 basic sizes and 16 alternative (low profile) sizes. The latter units have a distinctly rectangular cross-section in order to reduce the height while increasing the width, where site conditions require low profile units. In addition the units 3 and 4 modules high (670 and 830 mm for airflows up to 10000 m³/h) can be supplied without the base frame which reduces the height by a further 120 mm (to 550 and 710 mm respectively) thus facilitating ceiling mounted installation.

The maximum dimensions of the sections which compose the unit are designed to permit transport by container.

Face velocity [m/s]	Airflow							
	2		2.5		3		3.5	
	m ³ /h	m ³ /s	m ³ /h	m ³ /s	m ³ /h	m ³ /s	m ³ /h	m ³ /s
23LX								
0304	1068	0.297	1335	0.371	1602	0.445	1869	0.519
0404	1602	0.445	2002	0.556	2403	0.667	2803	0.779
0405	2197	0.610	2746	0.763	3295	0.915	3844	1.068
0406	2597	0.721	3246	0.902	3896	1.082	4545	1.263
0505	2929	0.814	3661	1.017	4393	1.220	5126	1.424
0407	3192	0.887	3990	1.108	4788	1.330	5586	1.552
0506	3463	0.962	4329	1.202	5194	1.443	6060	1.683
0408	3787	1.052	4734	1.315	5680	1.578	6627	1.841
0507	4256	1.182	5320	1.478	6384	1.773	7448	2.069
0409	4382	1.217	5477	1.521	6573	1.826	7668	2.130
0410	4977	1.382	6221	1.728	7465	2.074	8709	2.419
0508	5049	1.403	6312	1.753	7574	2.104	8836	2.454
0411	5572	1.548	6964	1.935	8357	2.321	9750	2.708
0509	5842	1.623	7303	2.029	8764	2.434	10224	2.840
0608	5891	1.636	7363	2.045	8836	2.454	10309	2.864
0412	6166	1.713	7708	2.141	9250	2.569	10791	2.998
0510	6636	1.843	8294	2.304	9953	2.765	11612	3.226
0413	6761	1.878	8452	2.348	10142	2.817	11832	3.287
0708	7153	1.987	8941	2.484	10730	2.980	12518	3.477
0511	7429	2.064	9286	2.579	11143	3.095	13000	3.611
0512	8222	2.284	10277	2.855	12333	3.426	14388	3.997
0808	8640	2.400	10800	3.000	12960	3.600	15120	4.200
0513	9015	2.504	11269	3.130	13522	3.756	15776	4.382
0612	9592	2.664	11990	3.331	14388	3.997	16786	4.663
0809	10022	2.784	12528	3.480	15034	4.176	17539	4.872
0613	10517	2.922	13147	3.652	15776	4.382	18406	5.113
0810	11405	3.168	14256	3.960	17107	4.752	19958	5.544
0712	11648	3.235	14559	4.044	17471	4.853	20383	5.662
0713	12771	3.548	15964	4.434	19157	5.321	22350	6.208
0811	12787	3.552	15984	4.440	19181	5.328	22378	6.216
0812	14170	3.936	17712	4.920	21254	5.904	24797	6.888
0813	15552	4.320	19440	5.400	23328	6.480	27216	7.560
1012	17712	4.920	22140	6.150	26568	7.380	30996	8.610
1013	19440	5.400	24300	6.750	29160	8.100	34020	9.450
1212	21254	5.904	26568	7.380	31882	8.856	37195	10.332
1213	23328	6.480	29160	8.100	34992	9.720	40824	11.340
1214	25402	7.056	31752	8.820	38102	10.584	44453	12.348
1216	29549	8.208	36936	10.260	44323	12.312	51710	14.364
1416	34474	9.576	43092	11.970	51710	14.364	60329	16.758
1220	37843	10.512	47304	13.140	56765	15.768	66226	18.396
1420	44150	12.264	55188	15.330	66226	18.396	77263	21.462
1224	46138	12.816	57672	16.020	69206	19.224	80741	22.428
1424	53827	14.952	67284	18.690	80741	22.428	94198	26.166
1428	63504	17.640	79380	22.050	95256	26.460	111132	30.870

Range

AirFlows

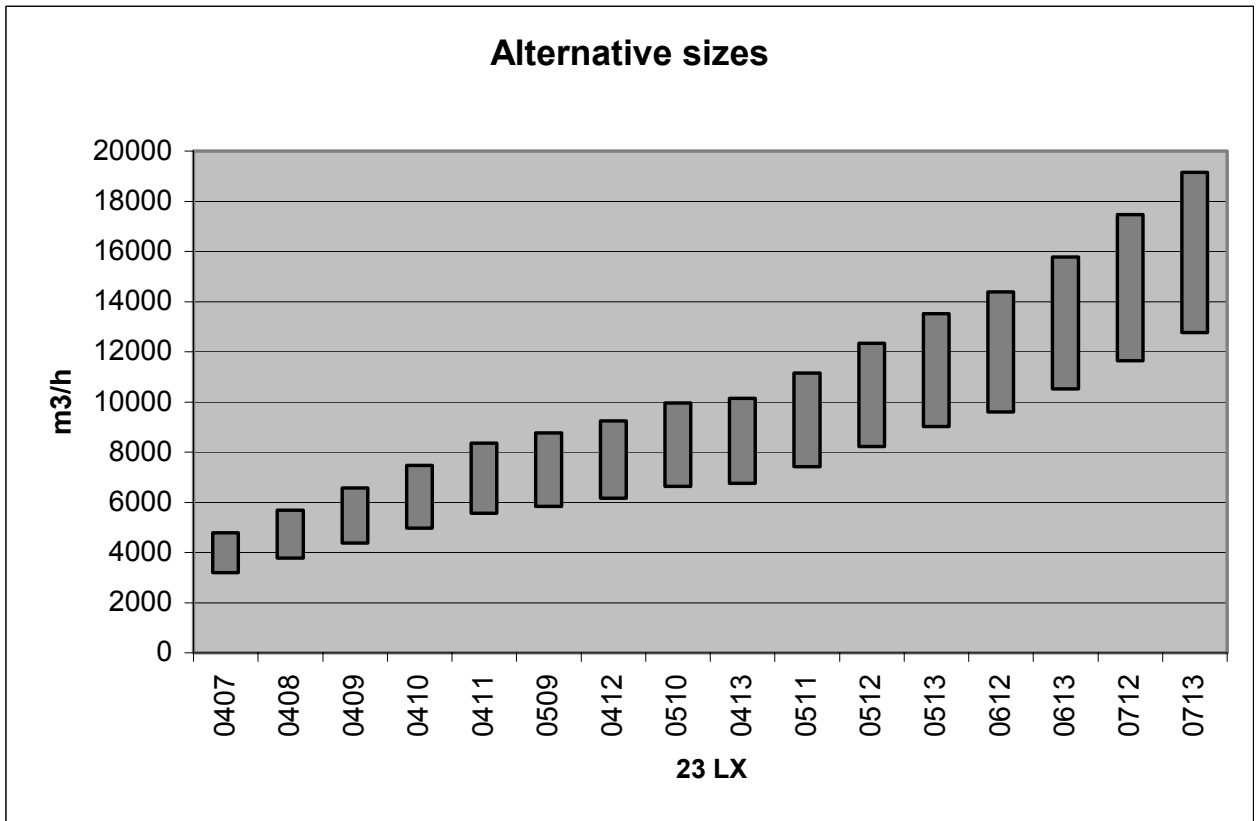
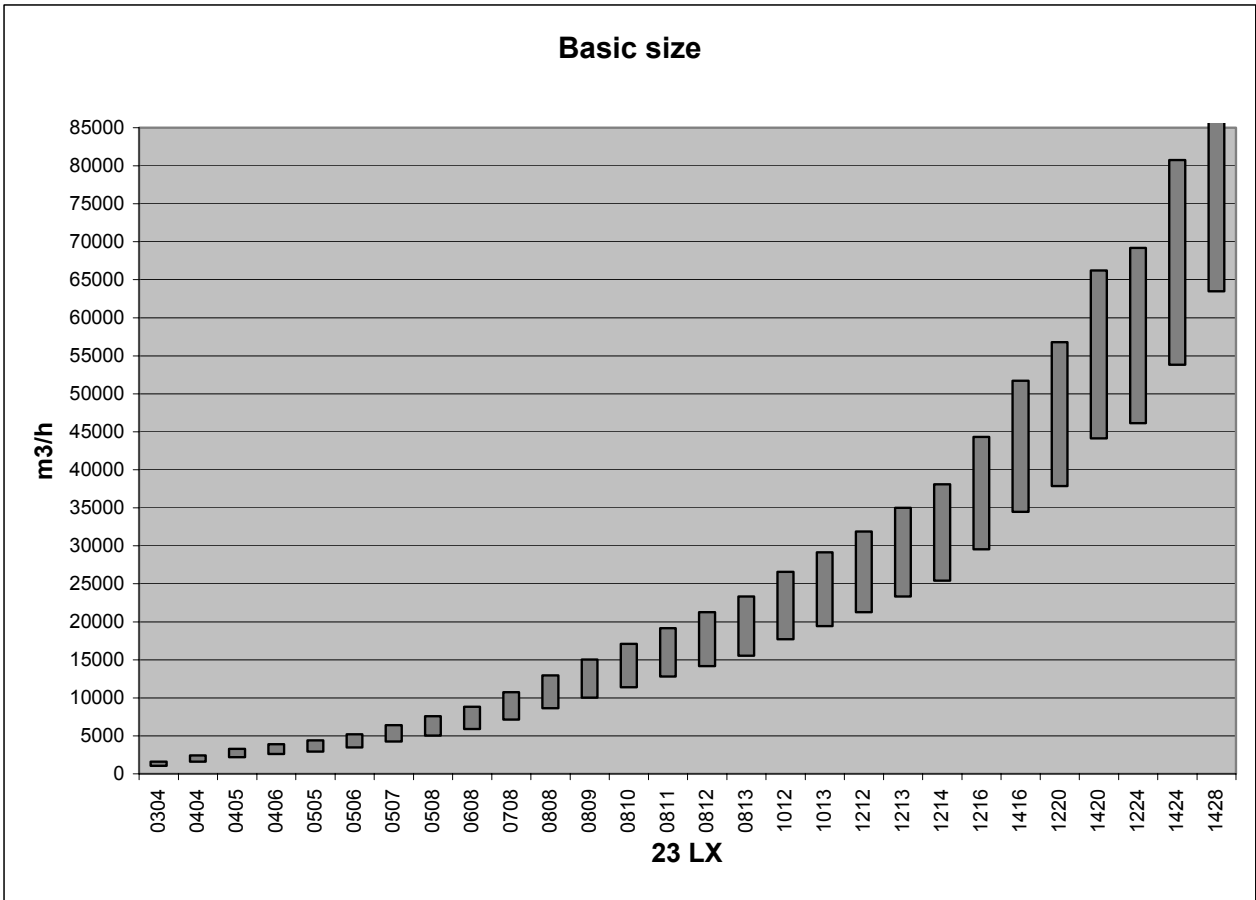

Dimensions

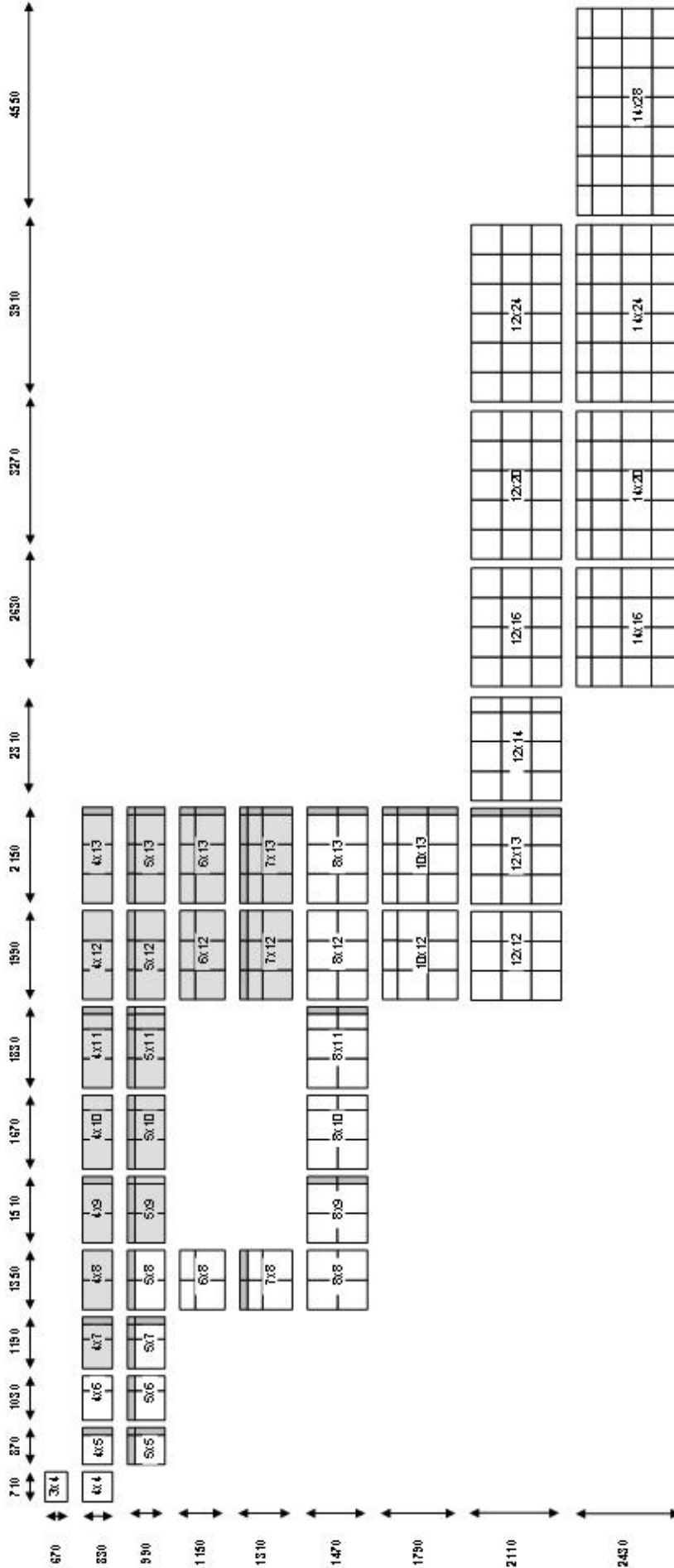

Gray shapes represent the alternative sizes.
 All heights include the 120 mm baseframe.
 Rectangles identify the standard filter frame dimensions,
 610x610 mm and 305 x 610 respectively.

UNIT CASING

Frame and panels

The construction consists of an aluminium frame with sandwich type panels.

The custom built exclusive profile, has the following advantages:

- Real 50 mm thick panels
- The internal surface of the unit is completely smooth
- No screws are visible inside the unit.
- Elimination of the thermal bridge effect.

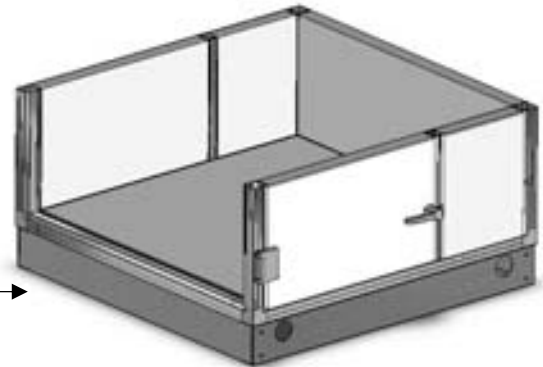

The 3-way corner joint is in glass fibre reinforced nylon.

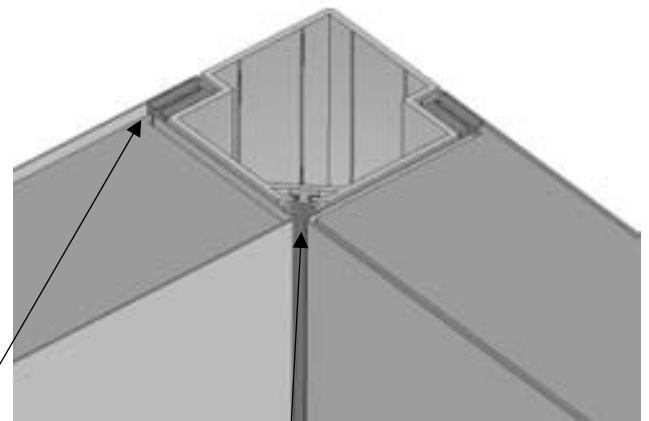
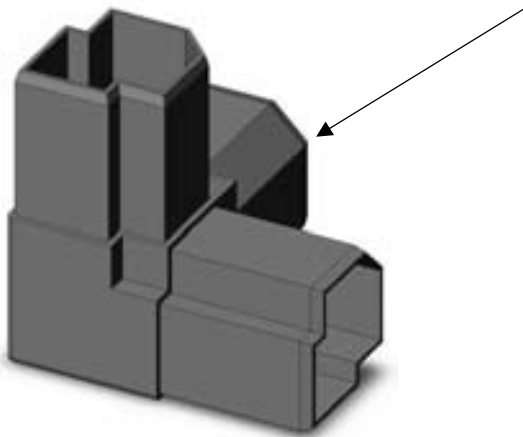

The gasket between the panels performs the double function of ensuring an airtight seal and eliminating thermal bridges.

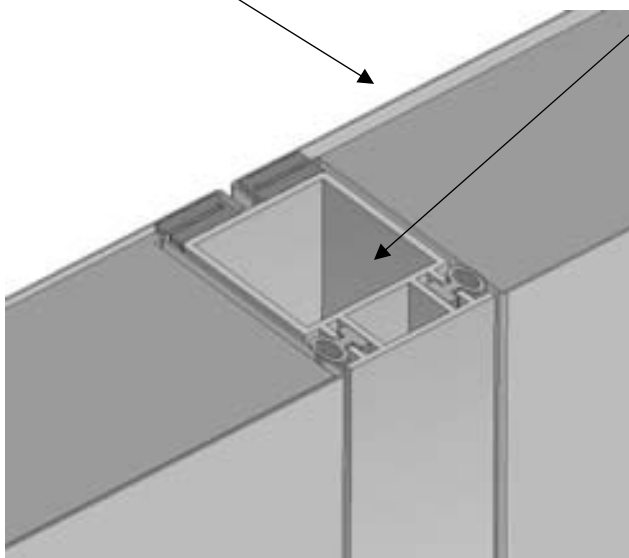

The gasket of the intermediate profiles eliminates contact between the treated air and the aluminium profile, thus improving the anti-thermal bridge effect, it further reduces air leakage and eliminates dust accumulation since there are no internal cracks.

Base Frame

The base frame consists of a galvanized steel “C” shaped frame 2 or 3 mm thick according to the unit length. The base frame is continuous around the unit’s perimeter and further transversal reinforcements are provided on the larger sections.

The base frame is always complete of four corner feet with lifting holes suitable for a 2” diameter thick walled steel pipe.

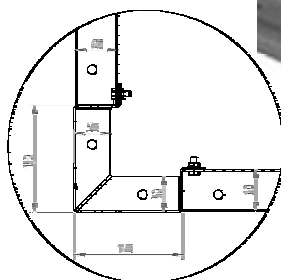

Section type	Size 23 LX	Section width [mm]	Footprint
Generic	all	≤ 1190	4 corner feet and 2 longitudinal spars
Generic	All		4 corner feet and 4 longitudinal spars
Cross flow heat exchanger	≤ 0713	>1190	4 corner feet

Roof

For external units a galvanized pre-painted steel roof is screwed to the frame of the unit.

The shelter extends at each side by 30 mm and is shaped for appropriate drainage.

A reversed “U” section covers the flanges between roof sections thus ensuring a watertight seal.

The corners are protected with plastic inserts for man-safe handling.



Auxiliary Sections

For external units it is possible to supply, on request, auxiliary sections mounted on the side of the unit to house control valves humidifiers or other equipment.

The depth of the auxiliary section depends on the diameter of the coil headers to ensure sufficient space for the control valves.

The Auxiliary section are constructed from the same materials as the airhandling unit and have removable panels on all three access sides.

The auxiliary sections do not have a floor panel in order to allow piping entry from below. Alternatively, the contractor make holes in the front or side panels according to site needs.



Handles, Hinges Inspection Ports And Lights

All inspection doors are mounted on 2 or 3 hinges and are equipped with 1 to 3 handles depending on the height of the door. In the sections under positive internal pressure, for safety reasons the doors are secured by knobs which are screwed to metal inserts. The same type of door fixture is also provided for 160mm wide doors used in flat, side withdrawal filter sections and for thermostat sections.

On request the doors can be fitted with double glazed polycarbonate inspection ports and lights.



Safety devices

The 23LX series is equipped with safety devices as stipulated by current regulations.

- On the access doors to all fan sections a micro switch and/or safety mesh is provided. The contact on the micro switch is opened when, to open the door, the screw which maintains the switch in the closed position, is unscrewed; in the time it takes to complete this operation the fan will be completely stopped.
- A copper cable ensures the earthing between the suspended fan base and the mounting frame.
- A stainless steel earthing bolt with two nuts and washer is provided on every section.
- The corners of the weathering roofs are provided with plastic inserts to prevent accidental cutting.



Panel types

Type	External wall		Internal wall		Insulation		Total thickness mm
	Material	Thickness mm	Material	Thickness mm	Material	Density Kg/m ³	
ZN06-ZN06-PU	Galvanized steel ZN 200	0.6	Galvanized steel ZN 200	0.6	Injected polyurethane	45	50
PV06-ZN06-PU	Galvanized steel ZN 200 prepainted	0.6	Galvanized steel ZN 200	0.6	Injected polyurethane	45	50
PV06-ZN10-PU	Galvanized steel ZN 200 prepainted	0.6	Galvanized steel ZN 200	1.0	Injected polyurethane	45	50
PV10-ZN10-PU	Galvanized steel ZN 200 prepainted	1.0	Galvanized steel ZN 200	1	Injected polyurethane	45	50
PV10-ZN15-PU	Galvanized steel ZN 200 prepainted	1.0	Galvanized steel ZN 200	1.5	Injected polyurethane	45	50
PV06-PV06-PU	Galvanized steel ZN 200 prepainted	0.6	Galvanized steel ZN 201	0.6	Injected polyurethane	45	50
PV06-IX06-PU	Galvanized steel ZN 200 prepainted	0.6	Stainless steel AISI304	0.6	Injected polyurethane	45	50
IX06-IX06-PU	Stainless steel AISI 304	0.6	Stainless steel AISI304	0.6	Injected polyurethane	45	50
PE08-PE08-PU	Aluminium	0.8	Aluminium	0.8	Injected polyurethane	45	50
PV06-ZN06-LM	Galvanized steel ZN 200 prepainted	0.6	Stainless steel AISI304	0.6	Rockwool	90	50
PV10-ZN15-LM	Galvanized steel ZN 200 prepainted	1	Stainless steel AISI304	1.5	Rockwool	90	50

Different types of panels for special applications can be made on request.

EN1886 Classification

Characteristics	Class (*)	
	STANDARD execution	THERMAL BREAK execution
Mechanical resistance	D1	D1
Leakage (negative/positive pressure)	L2	L2
Filter by pass	F9	F9
Transmittance	T2	T2
Thermal bridges	TB3	TB2

Classes refer to galvanized 0.6/galvanized 0.6/polyurethane panels.

Silencing effect (PV06-ZN06-PU)								
Wave length	Hz	125	250	500	1000	2000	4000	8000
Silencing effect	dB	8	8	13	15	16	31	36

Silencing effect (PV10-ZN15-LM)								
Wave length	Hz	125	250	500	1000	2000	4000	8000
Silencing effect	dB	11	12	14	21	26	31	32

Characteristics of the principal materials used

Material	Application	Properties	Units	Value/Class	Norm
Extruded aluminium	Unit frames, dampers	Alloy		9006/1	UNI
				6060	A.A.
		Physical state		T5	UNI 8278
		Unitary tensile breaking strain Rm	N/mm ²	185	
		Yield point Rp 0.2	N/mm ²	145	
		Elongation at breaking strength	%	11	
Galvanized steel	Panels, baseframes, internal members,	Hardness HB		55	
		Type		DX51D	EN 10142
		Galvanized		Z200 ? 14µm	
		Unitary tensile breaking strain Rm	N/mm ²	500	
Prepainted Steel	Panels	Yield point Rp 0.2	N/mm ²	300	
		Primer		epoxy base 5 µm	
		Paint finish		polyester 20 µm	
		Rear		Foamable epoxy base 0.7 µm	
		Finish thickness	µm	25	ECCA T1 / ISO 2808
		Brightness 60°	Gloss nominali	15-85	ECCA T2 / ISO 2813
		Polymerization grade MEK	Doppi sfregamenti	50	AICC 23
		Hardness HB	Grado koh-i-noor	F (min)	ECCA T4 / ASTM D3663
		Double impact resistance		6 J (min) (supporto 0.6	ECCA T5
		Adhesion after bending		T ? 1,5	ECCA T7
		Fissure formation after bending		T ? 3,0	ECCA T7
		Salt fog resistance		500 h without blisters	ECCA T8 / ASTM D 714
		100% relative humidity resistance		1000 h blister max 8 with slight softening	AICC 21 / ASTM D2247
		Resistance to artificial ageing (UVA)		test length 400 h	ECCA T10 / ASTM G 53 / ISO 4892
				brillantezza residua > 50%	
				slight flaking	
		Maximum working temperature (continuous)	°C	80	
Expanded polyurethane	Insulation of sandwich panels	Density	kh/m3	43,3	ISO 845
		Resistance to parallel compression	kg/cm ²	1,7	ISO 844
		Resistance to perpendicular compression	kg/cm ²	2,9	ISO 844
		Closed cells	%	97	ASTM D2856
		Initial thermal conductivity	W/mK	0,0246	ISO 8301
		Fire resistance	mm/s	41/48	ISO 3582
Rockwool	Insulation of sandwich panels, attenuator pods	Density	kh/m3	90	
		Initial thermal conductivity	W/mK	0,035	
		Fire resistance		Uninflammable class 0	ISO-DIS 1182,2
				Uninflammable class 1	DIN 4102
Polyester resin and fibreglass (Nylon)	Corner joints, hinges, handles	A1		EUROCLASSE	
		tensile resistance	Mpa	300 - 400	ASTM D 638
		Elastic module in stretching	Gpa	25 - 30	ASTM D 638
		Compression resistance	MPa	250 - 350	ASTM D 695
		elstric module in compression	GPa	15 - 25	ASTM D 695
		Resistenza a flessione	MPa	300 - 400	ASTM D 790
		Elastic module in flexing	GPa	ott-20	ASTM D 790
		Cut resistance	MPa	30	ASTM D 3846
		Tangential elastic module	GPa	3	-
		Resistenza all'urto	Kg cm / cm	> 150	ASTM D 256
		Barcol hardness	-	50	ASTM D 2583
		24 Water absorption in 24H	% max	0,2	ASTM D 570
		Density	g/cm	1,8 - 1,9	ASTM D 792
		Thermal expansion coefficient	cm / cm K	8 x 10-6	ASTM D 696
		Thermal conductance	Kcal / m h K	0,27	ASTM D 177
		Arc resistance	sec	120	ASTM D 495
		Electrical rigidity	Kv/mm	7	ASTM D 149
		Dialectric constant	a 50 Hz	5	ASTM D 150
		Surface insulation resistance	Ohm	1010 x 1013	DIN 53482
Loss factor at 50Hz	tg delta	0.03 - 0.04	DIN 53483		
Insulation class	-	F	F		

DUCTING CONNECTIONS EXTRACT, EXPULSION, SUPPLY

Types

There are many types and positions of ducting connections available according to site requirements. In particular, external units can be provided with dampers mounted inside the unit, in this case both the damper and its motor are protected from the weather. All the various standard types and positions are shown in the dimensional tables.

Dampers

Standard dampers are in aluminium with nylon gear wheels. On request we can supply levers in lieu of nylon gear wheels.

The dampers are supplied with an extended shaft for application of the damper motor or with manual lever (on request).



Internal dimensions Mm x mm	Type	Turning force Nm
1000 x 410	Single	2.5
1000 x 810	Single	3.5
1000 x 1210	Single	4.5
1000 x 1610	Single	6
1000 x 2010	Single	7
2000 x 410	Double	3
2000 x 810	Double	5
2000 x 1210	Double	7
2000 x 1610	Double	10
2000 x 2010	Double	12

Pressure drop	Pa	50	100	150	200	300	400	500	750	1000
Airflow	m ³ /h	6.5	9.6	12.6	15.5	21	26.1	30.8	40.8	48.4
Leakage at nominal airflow and 5 m/s face velocity		0.19%	0.29%	0.38%	0.46%	0.63%	0.78%	0.92%	1.22%	1.45%

Flexible connections

On request all ducting connections can be supplied with flexible connections in cloth with galvanized steel flanges complete with corner holes.

Fresh air intakes

On request fresh air inlets can be equipped with weathering cowls complete with anti-mesh.

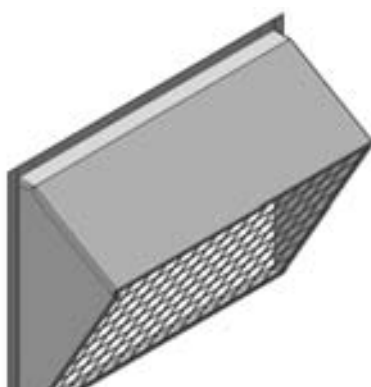

vermin

FILTERS

Various types of filters are available to satisfy the functions imposed by different applications.

Medium efficiency pleated filters

Synthetic: filters for large dust particles with galvanized steel frame, double mesh electro-welded supports, pleated synthetic fibre media.

Washable.

Classes: G3 and G4

Mounting: on slide rails or in frames if combined with a bag filter.

Withdrawal: side or front (air on side) if mounted in the same frame as a bag filter.

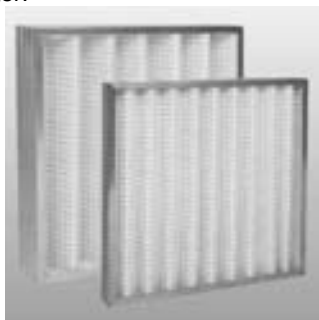

Types

Metallic: filters for large dust particles with galvanized steel frame and filter media in multi-layered flat aluminium wire.

Washable.

Class: G1

Mounting: on slide rails or in frames if combined with a bag filter.

Withdrawal: side or front (air on side) if mounted in the same frame as a bag filter.



Medium efficiency bag filters

Filters for large dust particles with galvanized steel frame, hot welded synthetic filter media.

Class: G4

Mounting: on slide rails.

Withdrawal: side.



Medium efficiency roll filter

Automatic roll filter complete with Galvanized steel casing, co-axial drive motor, adjustable pressure differential switch with a pressure range from 100 to 250 Pa, micro switch alarm for end of roll, control panel and roll of synthetic filter media.

The filter media is wound by means of a modular operator housed on the shaft of the filter roll which saves considerable space and reduces the level of risk normally associated with traditional mechanical components (chains cog wheels etc.) it is essentially composed of an asynchronous single phase motor (with absorbed power ranging from 140 to 240 W, protection IP44, insulation class H with incorporated thermal overload protection) a end of roll indicator, electromagnetic brake and a planetary reduction gear

Class: G3

Access: air on side

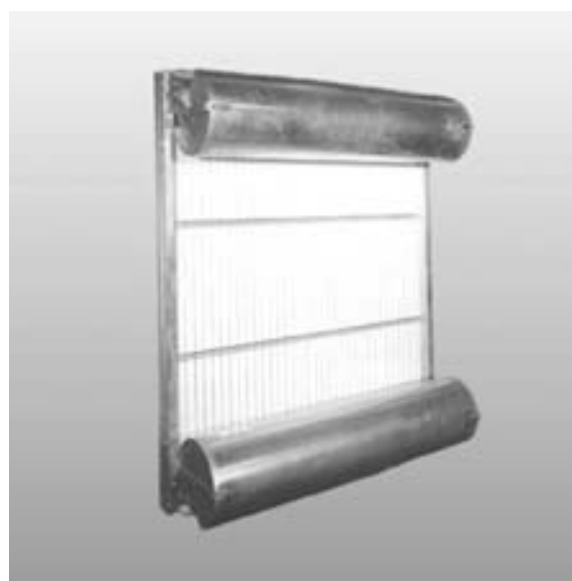

High efficiency bag filters

Hot welded bag filters for fine dust particles with galvanized steel frame, stratified synthetic fibre filter media.

Classes: F7, F8, F9

Mounting: in filter frames.

Withdrawal: front (air on side).

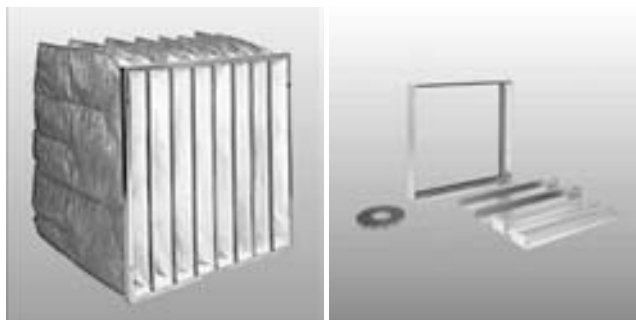

High efficiency rigid bag filters

Rigid bag filters for fine dust particles with plastic frame, fibreglass paper filter media with continuous spacer rods in thermoplastic material, polyurethane resin sealant.

Classes: F7, F8, F9

Mounting: in filter frames.

Withdrawal: front (air on side).



Semi absolute filters

Rigid semi-absolute filters with rigid plastic frames, fibreglass paper filter media with continuous spacer rods in thermoplastic material, polyurethane resin sealant.

Class: H10

Mounting: in filter frames.

Withdrawal: front (air on side)



Absolute filters

HEPA absolute filters with micropleated media, galvanized steel frame, filter media in fiberglass paper, with continuous spacer rods in thermoplastic material, polyurethane resin sealant.

Classes: H12, H13, H14

Mounting: in filter frames

Withdrawal: Front (air on side)



Carbon filters

Modules of cylindrical cartridges of active carbon mounted on a galvanized steel mounting plate by means of fixing pins, complete with neoprene gaskets.

Mounting: in frames

Withdrawal: rear (air off side)



Classification of filters

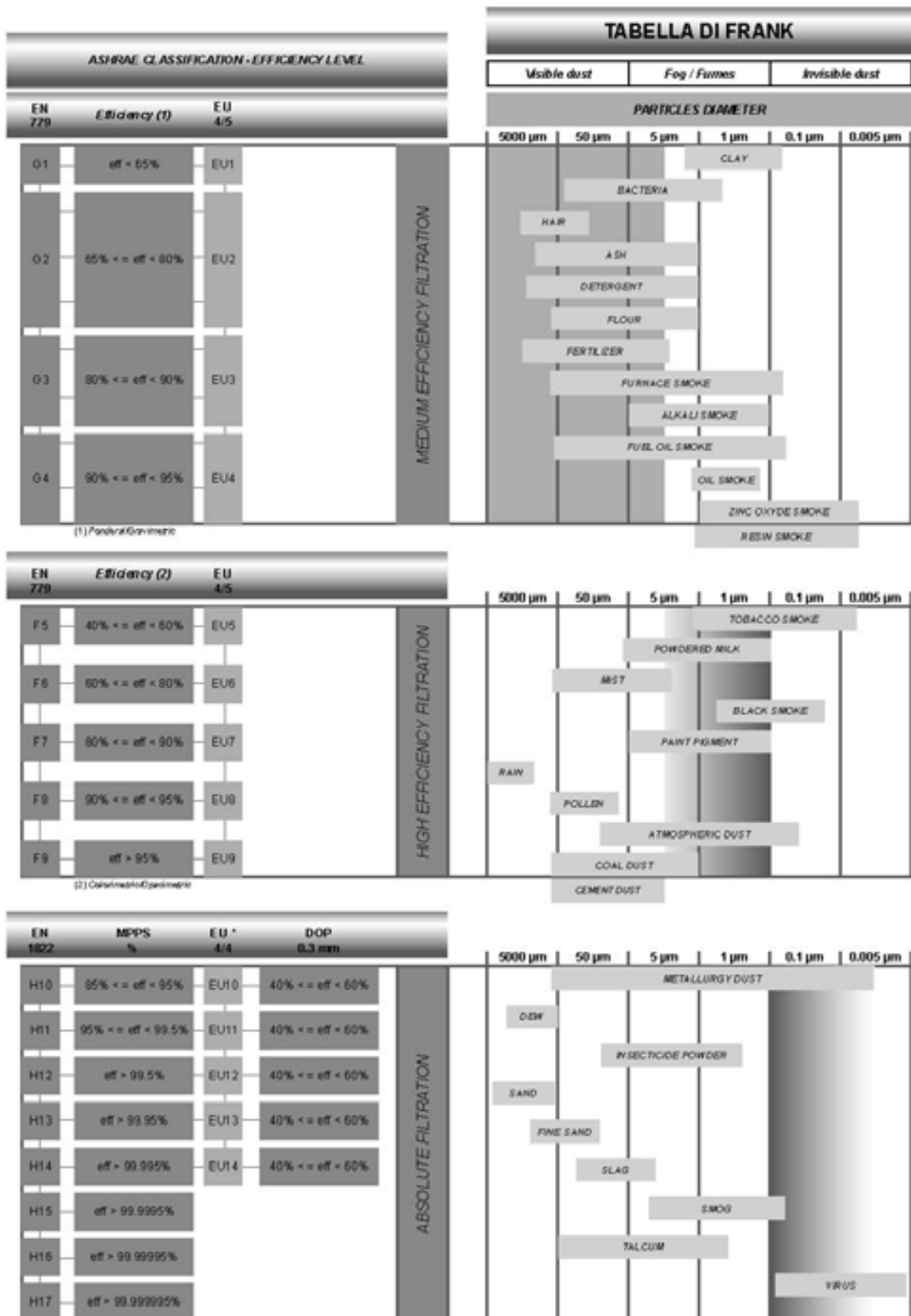

(*) There are no direct equivalents between EUROVENT 4/4 (EU10-11-12-13-14) and EN 1822 (H10-11-12-13-14).

Filter applications

FILTERS APPLICATIONS IN HVAC SYSTEMS IN ACCORDANCE WITH UNI 10339			
Categorical buildings classification (UNI 10339)	FILTERS CLASS		FILTRATION EFFICIENCY
	MIN	MAX	
Residential and similar buildings:			
Civil habitation, colleges, care homes	4	7	M ⁽¹⁾ , M+A
Prisons, barracks, convents	4	7	M+A
Hotels, hostels	5	7	M+A
Office buildings and similar:			
General offices	5	7	M+A
Reunion halls	5	7	M+A
Data centers	6	9	M+A
Office buildings and similar:			
Hospital rooms (2-3 beds), wards	6	8	M+A
Sterile rooms	10	12	M+A+AS
Maternity, anaesthetics and radiation	10	12	M+A+AS
Operating rooms	12	14	M+A+AS
Clinics, medical visiting rooms	6	8	M+A
Waiting and physical therapy	6	8	M+A
Buildings for recreation and religion			
Cinemas, theatres, congress halls	5	6	M+A
Museums, libraries	7	9	M+A
Churches	4	6	M ⁽¹⁾ , M+A
Pubs	3	5	M ⁽¹⁾ , M+A
Cafes, restaurants	5	6	M+A
Dance halls	3	5	M ⁽¹⁾ , M+A
Kitchens	2	4	M
Office buildings and similar			
Supermarkets, general shops	4	6	M ⁽¹⁾ , M+A
Food shops	5	6	M+A
Photographers, chemist	5	6	M+A
Public zones in banks	4	6	M ⁽¹⁾ , M+A
Exhibition centres	2	3	M
Buildings for sporting activities			
Swimming pools, saunas and similar	4	6	M ⁽¹⁾ , M+A
Gyms and similar	2	4	M
Office buildings and similar			
Nursery and primary schools	7	9	M+A
General halls	5	6	M+A
Music and language halls	6	7	M+A
Laboratories	6	7	M+A

(1) Used for filters up to class 4.

Legenda: M = Medium Eff.; A = High Eff.; AS = Absolute filtration.

Quantity and dimensions of filter cells

23 LX	Flat filters			Carbon filters		Roll filters			
	Bag filters								
	Rigid bag filters								
	Absolute filter								
	Cell 595 x 595	Cell 290 x 595	Front section	Cartridges 140 x 400		Rolls		Front section	Media direction
Cantidad	Cantidad	m ²		Wt.kg	Dimension	Cantidad	m ²		
0304	0	1	0.170	5	25.6				
0404	1	0	0.350	16	51.5				
0405	1	0	0.350	16	51.2				
0406	1	1	0.520	24	76.8				
0407	1	1	0.520	24	76.8				
0408	2	0	0.701	32	102.4				
0409	2	0	0.701	32	102.4				
0410	2	1	0.871	40	128				
0411	2	1	0.871	40	128				
0412	3	0	1.051	48	153.6				
0413	3	0	1.051	48	153.6				
0505	1	0	0.350	16	51.2				
0506	1	1	0.520	24	76.8				
0507	1	1	0.520	24	76.8				
0508	2	0	0.701	32	102.4	630	1	0.756	Horizontal
0509	2	0	0.701	32	102.4	630	1	0.882	Horizontal
0510	2	1	0.871	40	128	630	1	0.945	Horizontal
0511	2	1	0.871	40	128	630	1	1.071	Horizontal
0512	3	0	1.051	48	153.6	630	1	1.134	Horizontal
0513	3	0	1.051	48	153.6	630	1	1.26	Horizontal
0608	2	2	1.041	48	153.6	930	1	1.116	Horizontal
0612	3	3	1.561	72	230.4	930	1	1.674	Horizontal
0613	3	3	1.561	72	230.4	930	1	1.86	Horizontal
0708	2	2	1.041	48	153.6	930	1	1.116	Horizontal
0712	3	3	1.561	72	230.4	930	1	1.674	Horizontal
0713	3	3	1.561	72	230.4	930	1	1.86	Horizontal
0808	4	0	1.402	64	204.8	1230	1	1.476	Vertical
0809	4	0	1.402	64	204.8	1230	1	1.476	Vertical
0810	4	2	1.742	80	256	1530	1	1.836	Vertical
0811	4	2	1.742	80	256	1530	1	1.836	Vertical
0812	6	0	2.103	96	307.2	1830	1	2.196	Vertical
0813	6	0	2.103	96	307.2	1830	1	2.196	Vertical
1012	6	3	2.612	120	384	1830	1	2.745	Vertical
1013	6	3	2.612	120	384	1830	1	2.745	Vertical
1212	9	0	3.154	144	460.8	1830	1	3.294	Vertical
1213	9	0	3.154	144	430.8	1830	1	3.294	Vertical
1214	9	3	3.664	168	537.6	2130	1	3.834	Vertical
1216	12	0	4.206	192	614.4	1230	2	4.428	Vertical
1220	15	0	5.257	240	768	1530	2	5.508	Vertical
1224	18	0	6.308	288	921.6	1830	2	6.588	Vertical
1416	12	4	4.885	224	716.8	1230	2	5.412	Vertical
1420	15	5	6.106	280	896	1530	2	6.732	Vertical
1424	18	6	7.328	336	1075.2	1830	2	8.052	Vertical
1428	21	7	8.549	392	1254.4	2130	2	9.372	Vertical

Filter type	Thickness/Length
Flat	48
Bag	535
Rigid bag	290
Semi-absolute	290
Absolute	290
Carbon	400

COILS

Introduction

Thermal transfer is ensured by the following types of finned coils:

		water	direct expansion	steam	electric
heating		•		•	•
cooling		•	•		
geometry		P3012	P3012	P6030	
pipe diameter	mm	12	12	16	
pipe thickness	mm				
fin spacing	mm	2 - 2.5 - 3 - 4	2 - 2.5 - 3 - 4	2.05	
pipe material		Cu	Cu	Fe	Fe
fin material		Al-Cu-CuSn-CuPV	Al-Cu-CuSn-CuPV	Al	Fe

Each coil is housed in a separate section on slide rails. For easier maintenance, each coil has a separate frontal panel.

The coil headers are supplied complete with nipples for venting and drainage.

Water and direct expansion cooling coils have holes in the lower frame plate to allow the drainage of condensate to the drain pan.

Standard coils are subjected to a pneumatic pressure test at a pressure of 30 Bar by injecting with dry air while the coil is immersed in water.

Electric coils are dimensioned for a maximum internal temperature of 1280 °C and a maximum filament density of 4 W / cm³.

Electric coils are complete with a safety thermostat with manual reset which must be wired by the installer by connecting the appropriate terminals on the coil.

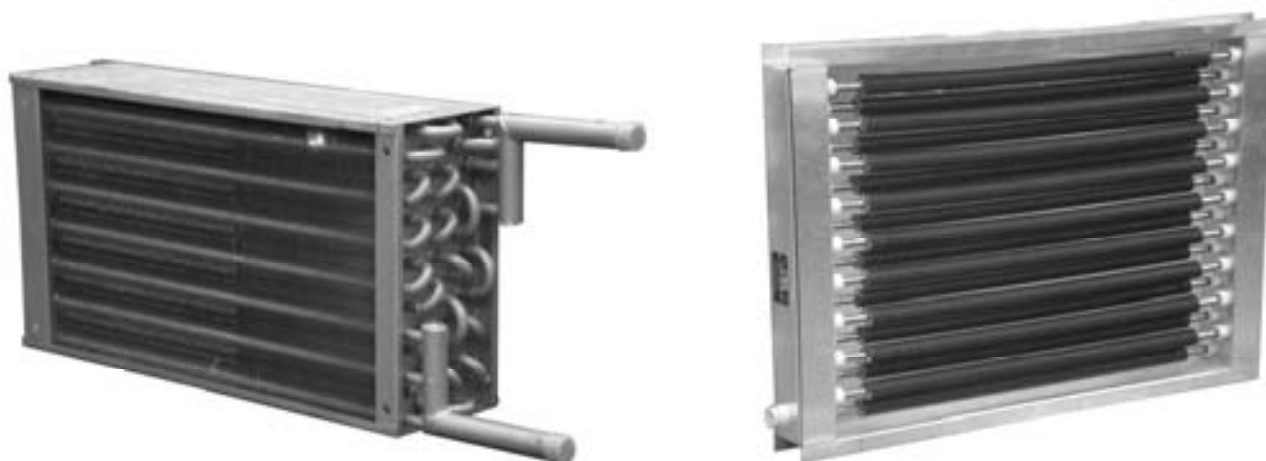

Dimensions of water, direct expansion and steam coils

23LX	Water			Heating pipe double		
	Direct expansion					
	Steam			Length	Height	Front section
	Length	Height	Front section			
mm	mm	m ²	mm	mm	m ²	
0304	425	360	0.153	425	240	0.0102
0404	425	540	0.230	425	360	0.1530
0405	580	540	0.313	580	360	0.2090
0406	700	540	0.378	700	360	0.2520
0407	860	540	0.464	860	360	0.3100
0408	1020	540	0.551	1020	360	0.3670
0409	1180	540	0.637	1180	360	0.4250
0410	1340	540	0.724	1340	360	0.4820
0411	1500	540	0.810	1500	360	0.5400
0412	1635	540	0.883	1635	360	0.5890
0413	1795	540	0.969	1795	360	0.6460
0505	580	720	0.418	580	480	0.2780
0506	700	720	0.504	700	480	0.3360
0507	860	720	0.619	860	480	0.4130
0508	1020	720	0.734	1020	840	0.4900
0509	1180	720	0.850	1180	480	0.5660
0510	1340	720	0.965	1340	480	0.6430
0511	1500	720	1.080	1500	480	0.7200
0512	1635	720	1.177	1635	480	0.7850
0513	1795	720	1.292	1795	480	0.8620
0608	1020	840	0.857	1020	540	0.5510
0612	1635	840	1.373	1635	540	0.8830
0613	1795	840	1.508	1795	540	0.9690
0708	1020	1020	1.040	1020	600	0.6120
0712	1635	1020	1.668	1635	600	0.9810
0713	1795	1020	1.831	1795	600	1.0770
0808	1020	1200	1.224	1020	720	0.7340
0809	1180	1200	1.416	1180	720	0.8500
0810	1340	1200	1.608	1340	720	0.9650
0811	1500	1200	1.800	1500	720	1.0800
0812	1635	1200	1.962	1635	720	1.1770
0813	1795	1200	2.154	1795	720	1.2920
1012	1635	1500	2.453	1635	900	1.4720
1013	1795	1500	2.693	1795	900	1.6160
1212	1635	1800	2.943	1635	1200	1.9620
1213	1795	1800	3.231	1735	1200	2.1540
1214	1955	1800	3.519	1955	1200	2.3460
1216	2275	1800	4.095	2275	1200	2.7300
1220	2915	1800	5.247	2915	1200	3.4980
1224	3555	1800	6.399	3555	1200	4.2660
1416	2275	2100	4.778	2275	1200	2.7300
1420	2915	2100	6.122	2915	1200	3.4980
1424	3555	2100	7.466	3555	1200	4.2660
1428	4195	2100	8.810	4195	1200	5.0340

Dimensions of electric coils

23LX	Length	Height	Front section	Power	Stages	Elements	Power	Stages	Elements	Power	Stages	Elements	Power	Stages	Elements
	mm	mm	mm ²	kW	Nr	Nr	kW	Nr	Nr	kW	Nr	Nr	kW	Nr	Nr
0304	410	360	0.148	1.8	1	3	5.5	3	9	7.4	4	12	9.2	5	15
0404	410	540	0.221	3.7	2	6	7.4	4	12	11.1	6	18	14.8	4	24
0405	570	540	0.308	5.1	2	6	10.3	4	12	15.4	6	18	20.5	4	24
0406	680	540	0.367	6.1	2	6	12.2	4	12	18.4	6	18	24.5	4	24
0407	840	540	0.454	7.6	2	6	15.1	4	12	22.7	6	18	30.2	4	24
0408	1000	540	0.540	9.0	2	6	18.0	4	12	27.0	6	18	36.0	4	24
0409	1160	540	0.626	10.4	2	6	20.9	4	12	31.3	6	18	41.8	4	24
0410	1320	540	0.713	11.9	2	6	23.8	4	12	35.6	6	18	47.5	4	24
0411	1480	540	0.799	13.3	2	6	26.6	4	12	40.0	6	18	53.3	4	24
0412	1640	540	0.886	14.8	2	6	29.5	4	12	44.3	6	18	59.0	4	24
0413	1800	540	0.972	16.2	2	6	32.4	4	12	48.6	6	18	64.8	4	24
0505	570	720	0.410	7.7	3	9	12.8	5	15	20.5	4	24	25.7	5	30
0506	680	720	0.490	9.2	3	9	15.3	5	15	24.5	4	24	30.6	5	30
0507	840	720	0.605	11.3	3	9	18.9	5	15	30.2	4	24	37.8	5	30
0508	1000	720	0.720	13.5	3	9	22.5	5	15	36.0	4	24	45.0	5	30
0509	1160	720	0.835	15.7	3	9	26.1	5	15	41.8	4	24	52.2	5	30
0510	1320	720	0.950	17.8	3	9	29.7	5	15	47.5	4	24	59.4	5	30
0511	1480	720	1.066	20.0	3	9	33.3	5	15	53.3	4	24	66.6	5	30
0512	1640	720	1.181	22.1	3	9	36.9	5	15	59.0	4	24	73.8	5	30
0513	1800	720	1.296	24.3	3	9	40.5	5	15	64.8	4	24	81.0	5	30
0608	1000	840	0.840	13.5	3	9	27.0	6	18	36.0	4	24	54.0	6	36
0612	1640	840	1.378	22.1	3	9	44.3	6	18	59.0	4	24	88.6	6	36
0613	1800	840	1.512	24.3	3	9	48.6	6	18	64.8	4	24	97.2	6	36
0708	1000	1020	1.020	18.0	4	12	36.0	4	24	45.0	5	30	67.5	5	45
0712	1640	1020	1.673	29.5	4	12	59.0	4	24	73.8	5	30	110.7	5	45
0713	1800	1020	1.836	32.4	4	12	64.8	4	24	81.0	5	30	121.5	5	45
0808	1000	1140	1.140	18.0	4	12	36.0	4	24	54.0	6	36	72.0	4	48
0809	1160	1140	1.322	20.9	4	12	41.8	4	24	62.6	6	36	83.5	4	48
0810	1320	1140	1.505	23.8	4	12	47.5	4	24	71.3	6	36	95.0	4	48
0811	1480	1140	1.687	26.6	4	12	53.3	4	24	79.9	6	36	106.6	4	48
0812	1640	1140	1.870	29.5	4	12	59.0	4	24	88.6	6	36	118.1	4	48
0813	1800	1140	2.052	32.4	4	12	64.8	4	24	97.2	6	36	129.6	4	48
1012	1640	1440	2.362	36.9	5	15	73.8	5	30	110.7	5	45	147.6	5	60
1013	1800	1440	2.592	40.5	5	15	81.0	5	30	121.5	5	45	162.0	5	60
1212	1640	1740	2.854	44.3	6	18	88.6	6	36	147.6	5	60	177.1	6	72
1213	1800	1740	3.132	48.6	6	18	97.2	6	36	162.0	5	60	194.4	6	72
1214	1960	1740	3.410	52.9	6	18	105.8	6	36	176.4	5	60	211.7	6	72
1216	2280	1740	3.967	61.6	6	18	123.1	6	36	205.2	5	60	246.2	6	72
1220	2920	1740	5.081	78.8	6	18	157.7	6	36	262.8	5	60	315.4	6	72
1224	3560	1740	6.194	96.1	6	18	192.2	6	36	320.4	5	60	384.5	6	72
1416	2280	2040	4.651	82.1	4	24	153.9	5	45	205.2	5	60	287.3	7	84
1420	2920	2040	5.957	105.1	4	24	197.1	5	45	262.8	5	60	367.9	7	84
1424	3560	2040	7.262	128.2	4	24	240.3	5	45	320.4	5	60	448.6	7	84
1428	4200	2040	8.568	151.2	4	24	283.5	5	45	378.0	5	60	529.2	7	84

Dimensions of electric coils (cont'd)

23LX	Length	Height	Front section	Power	Stages	Elements	Power	Stages	Elements	Power	Stages	Elements	Power	Stages	Elements
	mm	mm	mm ²	kW	Nr	Nr	kW	Nr	Nr	kW	Nr	Nr	kW	Nr	Nr
0304	410	360	0.148	11.0	6.0	18.0	14.7	4.0	24.0	16.6	3.0	27.0	18.4	5.0	30.0
0404	410	540	0.221	18.5	5.0	30.0	22.2	6.0	36.0	27.8	5.0	45.0	29.6	4.0	48.0
0405	570	540	0.308	25.6	5.0	30.0	30.8	6.0	36.0	38.4	5.0	45.0	41.0	4.0	48.0
0406	680	540	0.367	30.6	5.0	30.0	36.8	6.0	36.0	45.9	5.0	45.0	49.0	4.0	48.0
0407	840	540	0.454	37.8	5.0	30.0	45.3	6.0	36.0	56.6	5.0	45.0	60.4	4.0	48.0
0408	1000	540	0.540	45.0	5.0	30.0	54.0	6.0	36.0	67.5	5.0	45.0	72.0	4.0	48.0
0409	1160	540	0.626	52.3	5.0	30.0	62.7	6.0	36.0	78.4	5.0	45.0	83.6	4.0	48.0
0410	1320	540	0.713	59.4	5.0	30.0	71.3	6.0	36.0	89.1	5.0	45.0	95.0	4.0	48.0
0411	1480	540	0.799	66.6	5.0	30.0	80.0	6.0	36.0	99.9	5.0	45.0	106.6	4.0	48.0
0412	1640	540	0.886	73.8	5.0	30.0	88.5	6.0	36.0	110.6	5.0	45.0	118.0	4.0	48.0
0413	1800	540	0.972	81.0	5.0	30.0	97.2	6.0	36.0	121.5	5.0	45.0	129.6	4.0	48.0
0505	570	720	0.410	30.8	6.0	36.0	38.6	5.0	45.0	46.3	6.0	54.0	51.4	5.0	60.0
0506	680	720	0.490	36.7	6.0	36.0	45.9	5.0	45.0	55.1	6.0	54.0	61.2	5.0	60.0
0507	840	720	0.605	45.7	6.0	36.0	56.7	5.0	45.0	68.0	6.0	54.0	75.6	5.0	60.0
0508	1000	720	0.720	54.0	6.0	36.0	67.5	5.0	45.0	81.0	6.0	54.0	90.0	5.0	60.0
0509	1160	720	0.835	62.6	6.0	36.0	78.3	5.0	45.0	94.0	6.0	54.0	104.4	5.0	60.0
0510	1320	720	0.950	71.3	6.0	36.0	89.1	5.0	45.0	106.9	6.0	54.0	118.8	5.0	60.0
0511	1480	720	1.066	79.9	6.0	36.0	99.9	5.0	45.0	119.9	6.0	54.0	133.2	5.0	60.0
0512	1640	720	1.181	88.6	6.0	36.0	110.7	5.0	45.0	132.8	6.0	54.0	147.6	5.0	60.0
0513	1800	720	1.296	97.2	6.0	36.0	121.5	5.0	45.0	145.8	6.0	54.0	162.0	5.0	60.0
0608	1000	840	0.840	67.5	5.0	45.0	81.0	6.0	54.0	90.0	5.0	60.0	108.0	6.0	72.0
0612	1640	840	1.378	110.8	5.0	45.0	132.9	6.0	54.0	147.7	5.0	60.0	177.2	6.0	72.0
0613	1800	840	1.512	121.5	5.0	45.0	145.8	6.0	54.0	162.0	5.0	60.0	194.4	6.0	72.0
0708	1000	1020	1.020	81.0	6.0	54.0	90.0	5.0	60.0	112.5	5.0	75.0	135.0	6.0	90.0
0712	1640	1020	1.673	132.8	6.0	54.0	147.6	5.0	60.0	184.5	5.0	75.0	221.4	6.0	90.0
0713	1800	1020	1.836	145.8	6.0	54.0	162.0	5.0	60.0	202.5	5.0	75.0	243.0	6.0	90.0
0808	1000	1140	1.140	90.0	4.0	40.0	108.0	4.0	72.0	126.0	4.0	84.0	144.0	4.0	96.0
0809	1160	1140	1.322	104.4	4.0	60.0	125.3	4.0	72.0	146.1	4.0	84.0	167.0	4.0	96.0
0810	1320	1140	1.505	118.8	4.0	60.0	142.5	4.0	72.0	166.3	4.0	84.0	190.0	4.0	96.0
0811	1480	1140	1.687	133.3	4.0	60.0	159.9	4.0	72.0	186.6	4.0	84.0	213.2	4.0	96.0
0812	1640	1140	1.870	147.6	4.0	60.0	177.2	4.0	72.0	206.7	4.0	84.0	236.2	4.0	96.0
0813	1800	1140	2.052	162.0	4.0	60.0	194.4	4.0	72.0	226.8	4.0	84.0	259.2	4.0	96.0
1012	1640	1440	2.362	184.5	5.0	75.0	221.4	5.0	90.0	258.3	5.0	105.0	295.2	5.0	120.0
1013	1800	1440	2.592	202.5	5.0	75.0	243.0	5.0	90.0	283.5	5.0	105.0	324.0	5.0	120.0
1212	1640	1740	2.854	221.4	6.0	90.0	265.7	6.0	108.0	309.9	6.0	126.0	354.2	6.0	144.0
1213	1800	1740	3.132	243.0	6.0	90.0	291.6	6.0	108.0	340.2	6.0	126.0	388.8	6.0	144.0
1214	1960	1740	3.410	264.6	6.0	90.0	317.6	6.0	108.0	370.5	6.0	126.0	423.4	6.0	144.0
1216	2280	1740	3.967	307.8	6.0	90.0	369.3	6.0	108.0	430.9	6.0	126.0	492.4	6.0	144.0
1220	2920	1740	5.081	394.3	6.0	90.0	473.1	6.0	108.0	552.0	6.0	126.0	630.8	6.0	144.0
1224	3560	1740	6.194	480.6	6.0	90.0	576.8	6.0	108.0	672.9	6.0	126.0	769.0	6.0	144.0
1416	2280	2040	4.651	369.4	6.0	108.0	431.0	6.0	126.0	492.5	6.0	144.0	574.6	4.0	168.0
1420	2920	2040	5.957	473.0	6.0	108.0	551.9	6.0	126.0	630.7	6.0	144.0	735.8	4.0	168.0
1424	3560	2040	7.262	576.8	6.0	108.0	672.9	6.0	126.0	769.0	6.0	144.0	897.2	4.0	168.0
1428	4200	2040	8.568	680.4	6.0	108.0	793.8	6.0	126.0	907.2	6.0	144.0	1058.4	4.0	168.0

Dimensions of electric coils (cont'd)

23LX	Length	Height	Front section	Power	Stages	Elements	Power	Stages	Elements
	mm	mm	mm ²	kW	Nr	Nr	kW	Nr	Nr
0304	410	360	0.148	22.1	6.0	36.0	29.4	4.0	48.0
0404	410	540	0.221	37.0	5.0	60.0	46.3	5.0	75.0
0405	570	540	0.308	51.3	5.0	60.0	64.1	5.0	75.0
0406	680	540	0.367	61.3	5.0	60.0	76.6	5.0	75.0
0407	840	540	0.454	75.5	5.0	60.0	94.4	5.0	75.0
0408	1000	540	0.540	90.0	5.0	60.0	112.5	5.0	75.0
0409	1160	540	0.626	104.5	5.0	60.0	130.6	5.0	75.0
0410	1320	540	0.713	118.8	5.0	60.0	148.4	5.0	75.0
0411	1480	540	0.799	133.3	5.0	60.0	166.6	5.0	75.0
0412	1640	540	0.886	147.5	5.0	60.0	184.4	5.0	75.0
0413	1800	540	0.972	162.0	5.0	60.0	202.5	5.0	75.0
0505	570	720	0.410	64.3	5.0	75.0	77.1	6.0	90.0
0506	680	720	0.490	76.5	5.0	75.0	91.8	6.0	90.0
0507	840	720	0.605	94.5	5.0	75.0	113.4	6.0	90.0
0508	1000	720	0.720	112.5	5.0	75.0	135.0	6.0	90.0
0509	1160	720	0.835	130.5	5.0	75.0	156.6	6.0	90.0
0510	1320	720	0.950	148.5	5.0	75.0	178.2	6.0	90.0
0511	1480	720	1.066	166.5	5.0	75.0	199.8	6.0	90.0
0512	1640	720	1.181	184.5	5.0	75.0	221.4	6.0	90.0
0513	1800	720	1.296	202.5	5.0	75.0	243.0	6.0	90.0
0608	1000	840	0.840	135.0	6.0	90.0	162.0	6.0	108.0
0612	1640	840	1.378	221.5	6.0	90.0	265.8	6.0	108.0
0613	1800	840	1.512	243.0	6.0	90.0	291.6	6.0	108.0
0708	1000	1020	1.020	162.0	6.0	108.0	202.5	5.0	135.0
0712	1640	1020	1.673	265.7	6.0	108.0	332.1	5.0	135.0
0713	1800	1020	1.836	291.6	6.0	108.0	364.5	5.0	135.0
0808	1000	1140	1.140	180.0	5.0	120.0	243.0	6.0	162.0
0809	1160	1140	1.322	208.8	5.0	120.0	281.8	6.0	162.0
0810	1320	1140	1.505	237.5	5.0	120.0	320.6	6.0	162.0
0811	1480	1140	1.687	266.5	5.0	120.0	359.8	6.0	162.0
0812	1640	1140	1.870	295.3	5.0	120.0	398.6	6.0	162.0
0813	1800	1140	2.052	324.0	5.0	120.0	437.4	6.0	162.0
1012	1640	1440	2.362	369.0	5.0	150.0	487.1	6.0	198.0
1013	1800	1440	2.592	405.0	5.0	150.0	534.6	6.0	198.0
1212	1640	1740	2.854	442.8	6.0	180.0	575.6	6.0	234.0
1213	1800	1740	3.132	486.0	6.0	180.0	631.8	6.0	234.0
1214	1960	1740	3.410	529.3	6.0	180.0	688.0	6.0	234.0
1216	2280	1740	3.967	615.5	6.0	180.0	800.2	6.0	234.0
1220	2920	1740	5.081	788.5	6.0	180.0	1025.1	6.0	234.0
1224	3560	1740	6.194	961.3	6.0	180.0	1249.6	6.0	234.0
1416	2280	2040	4.651	738.8	6.0	216.0	985.0	6.0	288.0
1420	2920	2040	5.957	946.0	6.0	216.0	1261.4	6.0	288.0
1424	3560	2040	7.262	1153.5	6.0	216.0	1538.1	6.0	288.0
1428	4200	2040	8.568	1360.8	6.0	216.0	1814.4	6.0	288.0

CONDENSATE DRAIN PANS - DROPLET ELIMINATORS

Drain pans

The condensate drain pans are in aluminium or, on request in AISI304 stainless steel. The pans are inclined at 4° to ensure complete drainage through the 1" drain connection.

The drain connection for units up to 4 modules high (sizes 03xx and 04xx) is situated on the side of the unit to allow the unit to be installed in the ceiling mounting mode while limiting the height to 710 mm and covering airflow rates up to 10000 m³/h.



Droplet eliminators

Droplet eliminators can be chosen in either polypropelene or metal. The frame for both types is in metal according to the combinations shown in the table.

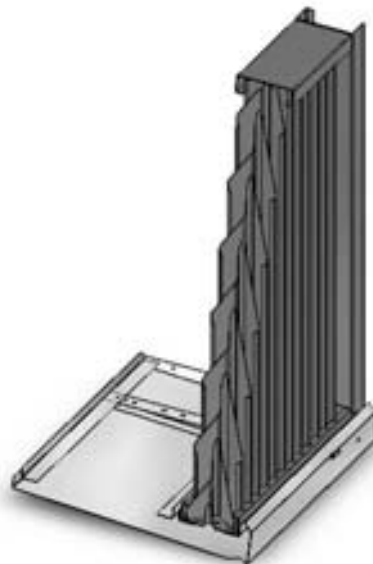
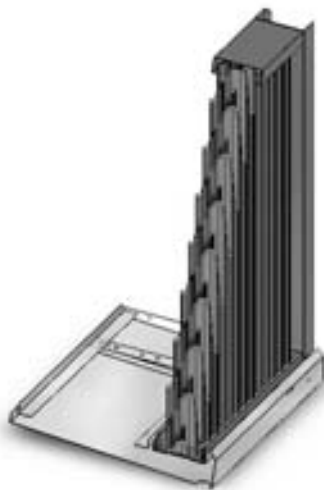

Eliminator composition		
Winglets		Casing
Plastic	Polypropylene	Galvanized steel
		Aluminium
		Stainless AISI 304
Steel	Galvanized steel	Galvanized steel
	Aluminium	Aluminium
	AISI 304	Stainless AISI 304

HUMIDIFIERS

Humidifiers with evaporating pack

Evaporating pack humidifiers can be supplied with a recirculating water pump or with water mains connection with water to the mains drain (waste water). The humidifying pack is in resin impregnated cellulose and can be supplied in 100 and 200 mm thicknesses.

The drain pans are in aluminium or, on request, in AISI304 stainless steel, with a 1" drain and overflow connection, 1/2" water connection situated in the unit base frame.

For face velocities above 2.5 m/s a droplet eliminator in materials as previously described will be installed.

Evaporating pack humidifiers with recirculated water are supplied with a pump and by-pass valve for regulating the water flow over the evaporating pack. The drain pan is complete with niche which houses the pump, stainless steel strainer, make-up ball valve, overflow and drain connections. The combination of drain pan and niche greatly reduces the amount of water present in the pan and since it is almost empty every time the pump is started the necessary bleed-off (to reduce the concentration of salts in the water and ensure a periodic water change) is guaranteed.

The mains waste water humidifiers are identical to the recirculating humidifiers as regards the water distribution over the evaporating pack but are supplied without isolating and regulating valves or other controls which should be supplied by the installer.

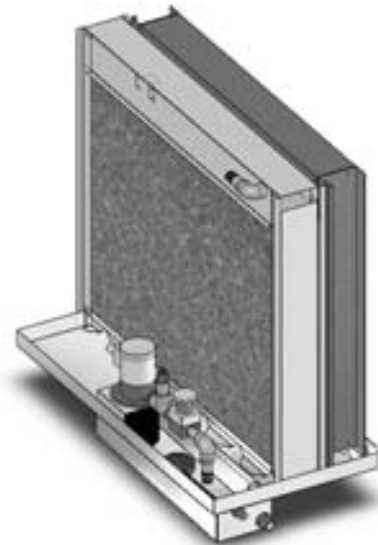
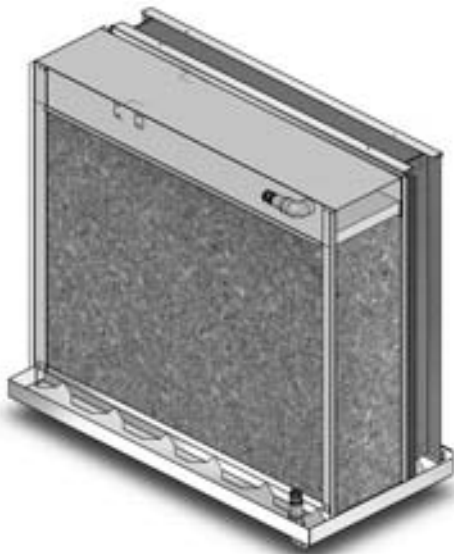
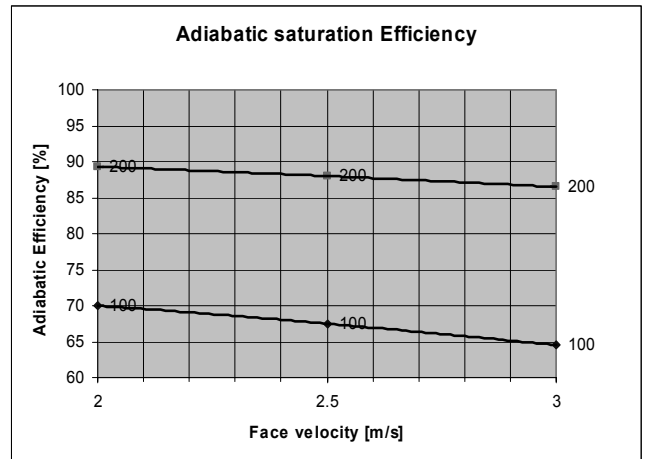

Steam humidifiers

Steam humidifiers can be supplied as follows:

- With only the steam distribution pipe which will be connected to the steam main and necessary regulating valves by the installer to.
- With steam distribution pipe and immersed electrode steam generator: the steam generator is supplied separately and will be mounted in the most convenient position by the installer. The generator must be connected by means of a high temperature pipe which is supplied. The generator is complete with electronic command and control and can receive a control signal of 0-10 V or 4-20 mA from a remote controller (not supplied).

The condensate drain pans are in aluminium or, on request in AISI304 stainless steel. The pans are inclined at 4° to ensure complete drainage through the 1" drain connection. The drain connection for units up to 4 modules high (sizes 03xx and 04xx) is situated on the side of the unit to allow the unit to be installed in the ceiling mounting mode while limiting the height to a maximum of 710 mm and covering airflow rates up to 10000 m³/h.

A droplet eliminator is supplied in one of the versions as previously described.

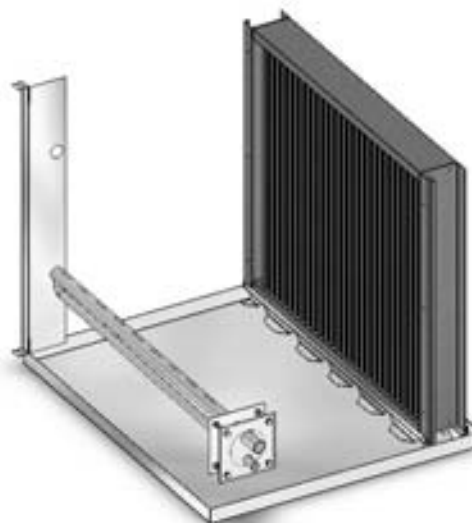

Immersed electrode steam generators

Capacity kg/h	Power kW	Supply current		
		V	Phase	Hz
1.5	1.12	230	1	50
3	2.25	400	3	50
5	3.75			
8	6			
10	7.5			
15	11.25			
25	18.75			
35	26.25			
45	33.75			
65	48.75			
90	67.5			
130	97.5			



Atomized water humidifiers

Atomized water humidifiers are composed of:

- pressurization cabinet, complete with filters, high pressure pump with inverter control, isolating valves and electrical control panel;
- Rack of stainless steel nozzles with regulating valve;
- High pressure supply pipe

The condensate drain pans are in aluminium or, on request in AISI304 stainless steel. The pans are inclined at 4° to ensure complete drainage through the 1" drain connection. The drain connection for units up to 4 modules high (sizes 03xx and 04xx) is situated on the side of the unit to allow the unit to be installed in the ceiling mounting mode while limiting the height to a maximum of 710 mm and covering airflow rates up to 10000 m³/h.

A droplet eliminator is supplied in one of the versions as previously described.

The supply water must have been subjected to osmotic water treatment to control the total water hardness from 0 to 25 ppm CaCO₃ and conductivity from 30 to 50 µS/cm. The necessary water treatment is not included and should be supplied by the installer.

POWER SUPPLY ; 400V/3/50Hz

23LX	Water flow	Pump power	Nozzles		Válves
	Kg/h	kW	N°	Kg/h at 70 bar	N°
0304	10.1	0.420	4	2.8	1
0404	15.2	0.420	7	2.8	1
0405	20.8	0.420	9	2.8	1
0406	24.6	0.420	10	2.8	2
0407	30.2	0.420	13	2.8	2
0408	35.8	0.420	15	2.8	2
0409	41.5	0.420	17	2.8	2
0410	47.1	0.420	19	2.8	2
0411	52.7	0.420	22	2.8	2
0412	57.8	0.420	23	2.8	2
0413	64.0	0.625	19	4	2
0505	32.1	0.420	13	2.8	1
0506	32.1	0.420	13	2.8	1
0507	40.3	0.420	16	2.8	1
0508	47.3	0.420	14	4	2
0509	55.3	0.420	16	4	2
0510	62.8	0.625	18	4	2
0511	70.3	0.625	19	4	2
0512	77.8	0.625	22	4	2
0513	85.3	0.625	23	4	2
0608	55.7	0.420	17	4	2
0612	82.5	0.625	23	4	2
0613	99.5	0.625	28	4	2
0708	67.7	0.625	19	4	2
0712	110.2	0.625	30	4	2
0713	113.6	0.625	32	4	2
0808	75.7	0.625	22	4	2
0809	87.5	0.625	25	4	2
0810	99.4	0.625	28	4	2
0811	111.3	0.625	31	4	2
0812	123.2	0.955	33	4	2
0813	135.1	0.955	37	4	2
1012	155.6	0.955	42	4	3
1013	170.6	0.955	46	4	3
1212	188.0	1.050	51	4	3
1213	206.2	1.050	56	4	3
1214	224.3	1.050	61	4	3
1216	260.6	1.050	71	4	4
1220	333.1	1.050	89	4	5
1224	388.9	1.050	104	4	4
1416	305.5	1.050	82	4	5
1420	390.6	1.050	105	4	5
1424	390.6	1.050	105	4	5
1428	390.6	1.050	105	4	5





Air washers

The air washers have a double chamber mounted over a water tank in AISI304 stainless steel. Two ramps of spray nozzles are mounted inside the chamber and are connected to a pump mounted outside the unit. The water level in the tank is maintained by means of a ball float valve. The water intake to the pump is protected by a stainless steel filter. An air straightener is mounted upstream of the first ramp of nozzles and a droplet eliminator is mounted downstream of the second bank.

POWER SUPPLY: 400V/3/50Hz.

23LX	Pump		Ramp nozzles	Nozzles	
	Water flow	Pump power		N°	Flow unit
	Kg/h	kW			Kg/h at 3 bar
0304	1600	0.55	2	2	0.37
0404	2300	0.55		2	
0405	3200	0.55		4	
0406	3800	0.75		4	
0407	4600	0.75		4	
0408	5500	1.1		6	
0409	6400	1.1		6	
0410	7200	1.5		6	
0411	8100	1.5		8	
0412	8800	1.5		8	
0413	9600	1.5		8	
0505	4200	0.75		4	
0506	5000	1.1		4	
0507	6200	1.1		6	
0508	7300	1.5		6	
0509	8500	1.5		8	
0510	9600	1.5		8	
0511	10700	2.2		10	
0512	11700	2.2		10	
0513	12800	2.2		10	
0608	8500	1.5		8	
0612	13600	2.2		12	
0613	15000	3		12	
0708	10300	2.2		8	
0712	16600	3		14	
0713	18200	3		14	
0808	12200	2.2		10	
0809	14100	3		12	
0810	16000	3		14	
0811	17900	3		14	
0812	19500	3		16	
0813	21400	4		18	
1012	24300	4		20	
1013	26700	4		22	
1212	29200	5.5	24		
1213	32000	5.5	26		
1214	34900	5.5	28		
1216	40600	7.5	32		
1220	52000	7.5	40		
1224	63400	11	50		
1416	47300	7.5	36		
1420	60700	11	46		
1424	74000	11	58		
1428	87300	15	68		

ENERGY RECOVERY

Cross flow heat exchangers

Cross flow heat exchangers can be supplied in 4 different configurations:

- Exhaust airflow above supply airflow below (piggy back);
- Exhaust and supply in line;
- Exhaust and supply in line with the possibility of inserting other components upstream of the heat exchanger in either of the airflows. In this configuration, unlike the others, there is no filter on the incoming fresh air in the heat exchange section;
- Exhaust and supply air side by side;

In the lower part of the section there is an aluminum or stainless steel AISI304 condensate tray, with a 1" drain connection.

The heat exchangers are available in three widths (rec1, rec2, rec3) according to the percentage of fresh air to be treated, and they are available with a simple or double by-pass (recommended when the fresh airflow is less than 30% of the total airflow).

All sections can be supplied with a recirculating damper.

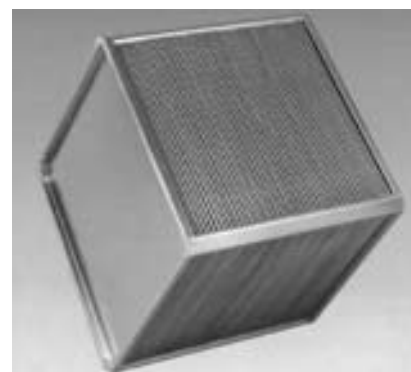

Size	"Piggy-back" or on line						Side by side				
	Rec1 (1)	Rec2	Rec3	Filter (2)			Size	Width Rec1 (1)	Filter		
				Cells	Front section				Cells	Front section	
mm	mm	mm	595x595	290x595	m ²	mm	595x595	290x595	m ²		
300	600	520	440	0	1	0.173	600	405	0	1	0.171
400	600	520	440	1	0	0.354	600	405	1	0	0.354
400	760	600	440	1	0	0.354	600	605	1	0	0.354
400	920	760	600	1	1	0.527	805	705	1	1	0.525
400	1080	920	760	1	1	0.527	805	705	1	1	0.525
400	1240	1080	920	2	0	0.708	1005	805	2	0	0.708
400	1400	1240	1080	2	0	0.708	1205	1005	2	0	0.708
400	1560	1240	920	2	1	0.881	1205	1205	2	1	0.879
400	1720	1400	1080	2	1	0.881	1205	1205	2	1	0.879
400	1880	1560	1240	3	0	1.062	1205	1205	3	0	1.062
400	2040	1720	1400	3	0	1.062	1205	1205	3	0	1.062
605	760	600	440	1	0	0.354	705	605	1	0	0.354
605	920	760	600	1	1	0.527	805	705	1	1	0.525
605	1080	920	760	1	1	0.527	805	705	1	1	0.525
605	1240	1080	920	2	0	0.708	1005	805	2	0	0.708
605	1400	1240	1080	2	0	0.708	1205	1005	2	0	0.708
605	1560	1240	920	2	1	0.881	1205	1205	2	1	0.879
605	1720	1400	1080	2	1	0.881	1205	1205	2	1	0.879
605	1880	1560	1240	3	0	1.062	1205	1205	3	0	1.062
605	2040	1720	1400	3	0	1.062	1205	1205	3	0	1.062
705	1240	1080	920	2	2	1.053	1005	805	2	2	1.05
705	1880	1560	1240	3	3	1.580	1205	1205	3	3	1.574
705	2040	1720	1400	3	3	1.580	1205	1205	3	3	1.574
705	1240	1080	920	2	2	1.053	1005	805	2	2	1.05
705	1880	1560	1240	3	3	1.580	1205	1205	3	3	1.574
705	2040	1720	1400	3	3	1.580	1205	1205	3	3	1.574
805	1240	1080	920	4	0	1.416	1005	805	4	0	1.416
805	1400	1240	1080	4	0	1.416	1005	1005	4	0	1.416
805	1560	1240	920	4	2	1.761	1205	1205	4	2	1.758
805	1720	1400	1080	4	2	1.761	1205	1205	4	2	1.758
805	1880	1560	1240	6	0	2.124	1205	1205	6	0	2.124
805	2040	1720	1400	6	0	2.124	1205	1205	6	0	2.124
1005	1880	1560	1240	6	3	2.642	1205	1205	6	3	2.636
1005	2040	1720	1400	6	3	2.642	1205	1205	6	3	2.636
1205	1880	1560	1240	9	0	3.186	1205	1205	9	0	3.186
1205	2040	1720	1400	9	0	3.186	1205	1205	9	0	3.186
1205	2200	1880	1560	9	3	3.704	1205	1205	9	3	3.699
1205	2520	2200	1880	12	0	4.248	-	-	-	-	-
1205	3160	2520	1880	15	0	5.310	-	-	-	-	-
1205	3800	3160	2520	18	0	6.372	-	-	-	-	-
1205	2520	2200	1880	12	4	4.939	-	-	-	-	-
1205	3160	2520	1880	15	5	6.173	-	-	-	-	-
1205	3800	3160	2520	18	6	7.408	-	-	-	-	-
1205	4440	3800	3160	21	7	8.642	-	-	-	-	-

(1) On total size (by pass damper included).

Heat wheels



This is the system with the highest efficiency presently available when there is energy transfer between two airstreams and can arrive at 75% efficiency in the most favourable summer or winter conditions. This type of energy recovery consists of a true wheel composed of pack of appropriately spaced circular fins, and is connected to an electric motor which can move the wheel at a constant or variable speed according to the needs of the system. Heat wheels can recover both sensible and latent energy (hygroscopic version).

It is highly recommended that both airflows should be equipped with a washable filter to maintain the maximum efficiency.

The position of the fans with respect to the heat wheel should be carefully examined to the best working conditions for the installation in question.

With reference to the illustrations:

Maximum level of self-cleaning.

The fans should be positioned as shown in illustrations A or B. Note that in the case A may cause a negative pressure in the building throughout the year. This is the most common fan positioning. The pressure can be reduced by installing a regulating damper in the exhaust air duct upstream of the heat wheel. If the exhaust air is contaminated and the recirculation of the air is not permitted it is necessary to maintain a pressure balance on both sides of the heat wheel. Pressure conditions:

($p_1 > p_4$) ($p_2 > p_3$).

Maximum cooling energy reclaim

If the fans are installed as shown in illustration B all the heat from the exhaust fan motor and almost all the heat from the supply fan motor will be dissipated in the exhaust airflow. This type of installation permits a constant pressure in the building throughout the year. Maximum cooling energy recovery is achieved if the fans are installed so that the heat in the exhaust air and the heat generated by the fan motors is removed by the exhaust air. This configuration is suitable when clean air is required. The position of the fans as shown in C could give rise to some problems when trying to balance the air pressures.

Maximum heating energy recovery

If the fans are positioned as shown in illustration D all the power of the exhaust fan motor and almost all the power of the supply fan motor will be recovered. This type of installation permits a constant pressure in the building throughout the year. Maximum heating energy recovery is achieved if the fans are installed so that the heat in the exhaust air and the heat generated by the fan motors is transferred to the fresh air. This configuration is only possible if recirculation of the air is permitted.

23LX	Wheel diameter	23LX	Wheel diameter
0304	500	0708	-
0404	500	0712	1700
0405	600	0713	1900
0406	800	0808	-
0407	900	0809	-
0408	1100	0810	1400
0409	1100	0811	1600
0410	1100	0812	1700
0411	1100	0813	1900
0412	1100	1012	1700
0413	1100	1013	1900
0505	-	1212	-
0506	800	1213	1900
0507	900	1214	2100
0508	1100	1216	-
0509	1200	1220	-
0510	1400	1224	-
0511	1400	1416	-
0512	1400	1420	-
0513	1400	1424	-
0608	1100	1428	-
0612	1700		
0613	1700		

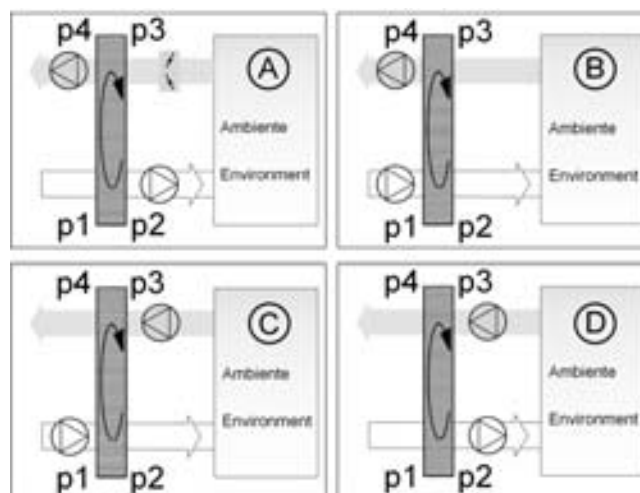

Run around coils

This system consists essentially of two water/air coils connected in a closed circuit on the water side of the coils and in different airflows on the air side of the coils.

The first coil is situated in the incoming fresh airflow and will provide pre-cooling in summer and pre-heating in winter. The second coil is situated in the exhaust airflow and will have an air heating effect in summer and an air cooling effect in winter. The purpose of the second coil is to change the temperature of the fluid in the closed circuit (normally a water and glycol mixture) so that the water/air energy transfer in the first coil changes the temperature of the incoming fresh air. This type of system can achieve efficiencies of 30 to 40% on the fresh air in normal thermo-hygrometric conditions and with the same airflow rate on both coils. The calculation normally results in 6 or 8 row coils but the system balances itself automatically due to the operating conditions to which the airhandling unit is subjected (air temperature). The system must be completed by the addition of water connections, circulating pump, expansion vessel and isolating and control valves all of which are not included in the supply.

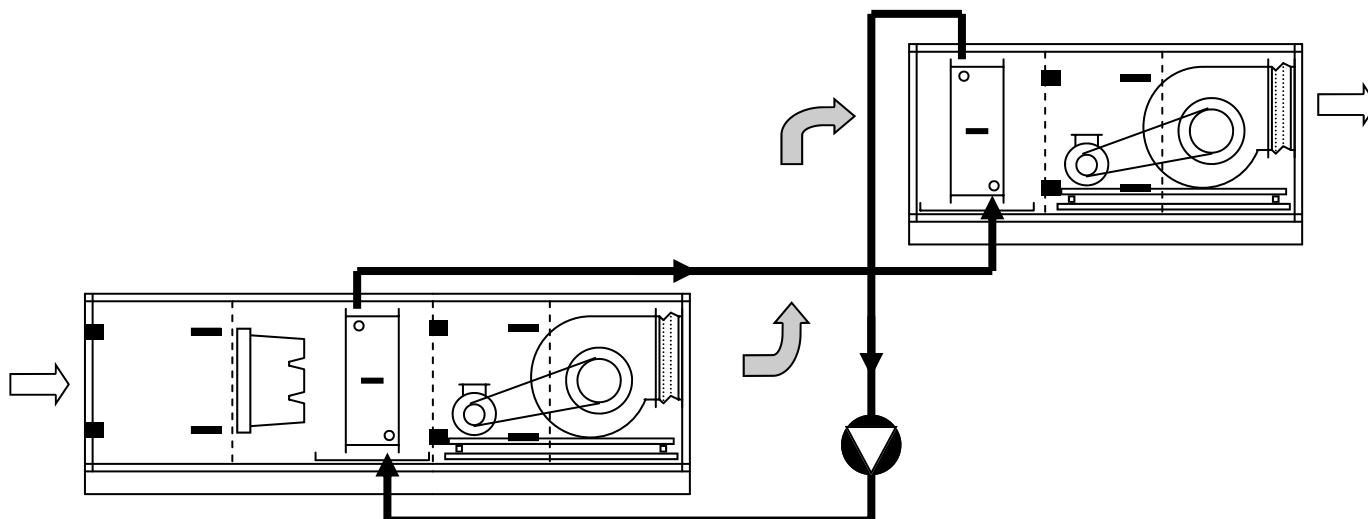

Heat pipes

The standard version of heat pipes for the 23LX series do not work with the exhaust airflow but provide a free reheat effect, absorbing the necessary heat from the air which has to be cooled and dehumidified. Their principal effect is to improve the dehumidification. Their use is therefore principally in installations with 100% fresh air, and in situations where summer air treatment is predominant.

Because of the space occupied at the rear of the heat pipe coils the standard length of the main cooling coil between the heat pipes is reduced by 60 mm.

On request it is possible to supply traditional fixed or tilting heat pipes which are installed in both fresh and exhaust airflows.

(1) Valid also for heat recovery with single and double by-pass, but as total measurement (by-pass damper included).

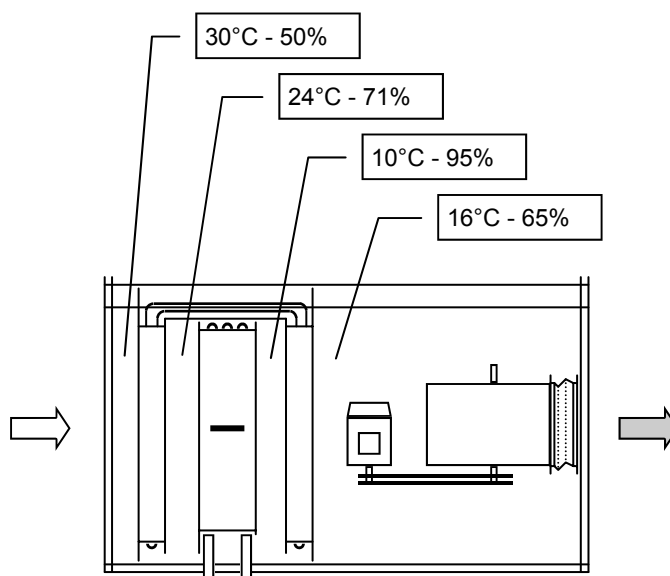

ATTENUATORS

Attenuators are available in four lengths and two different types. They are comprised of 90 kg/m³ rockwool pods 200 mm thick (100 mm for the first and last pods next to the attenuator walls) the distance between the pods is 100^{±10} mm.

The standard construction has rockwool pods with an outside coating glass fibre to prevent fibre migration. The hygienic version has the rockwool pods sealed with plastic material and kept in place with perforated plates.

EMPTY SECTIONS

Pods lengths mm	Acoustic effect at various frequencies								
	Hz	63	125	250	500	1000	2000	4000	8000
600	dB	3	5	11	18	25	28	20	18
900	dB	5	10	18	27	39	41	30	27
1200	dB	7	13	24	35	47	47	39	35
1500	dB	9	16	30	44	49	49	45	31

Empty sections are available for inspection, insertion of future components or for use as distance pieces to straighten airflow. The sections are as shown in the following table.

Type	Section length (mm)					
		160	320	480	640	960
Empty section			•		•	
Empty section with door					•	
Empty section with door Under positive pressure					•	
Empty section with drain pan for future cooling coil					•	
Empty section pan for humidification						•
Section for air straighteners	23LX	03xx-04xx	05xx-06xx-07xx	08xx-10xx	12xx-14xx	
		•	•	•	•	
Drawer section for thermostat mounting		•				

The length of the sections for use as air straighteners downstream of the fans depends on the height of the unit as shown in the table. The thermostat insertion section includes a perforated screen of the same size as the unit cross-section to which the capillary tube of the thermostat can be fixed. The thermostat itself is fixed to the unit's outside panel and the whole assembly may be withdrawn for installation or replacement of the thermostat.

FAN SECTIONS

Introduction

The fan sections are comprised of the following components:

- Fan
- Electric motor
- Motor slide rail
- Belt drive transmission
- Base frame with antivibration mounts
- Flexible connection on the fan outlet
- Earthing cable on the fan and motor base frame

In the case of section with plug fans, there is no transmission since the drive motor is mounted directly on the fan shaft. An inverter can be supplied for controlling the motor speed.

Where specifications call for a standby fan and motor for emergency operation such as operating theatres. The fan section is fitted with two fan and motor sets. In this case the fan outlets are equipped with dampers on the fan outlets but it is also possible to provide dampers on the fan inlets and fit a dividing wall between the two fan sets in order to carry out maintenance on one fan set whilst the other is running.

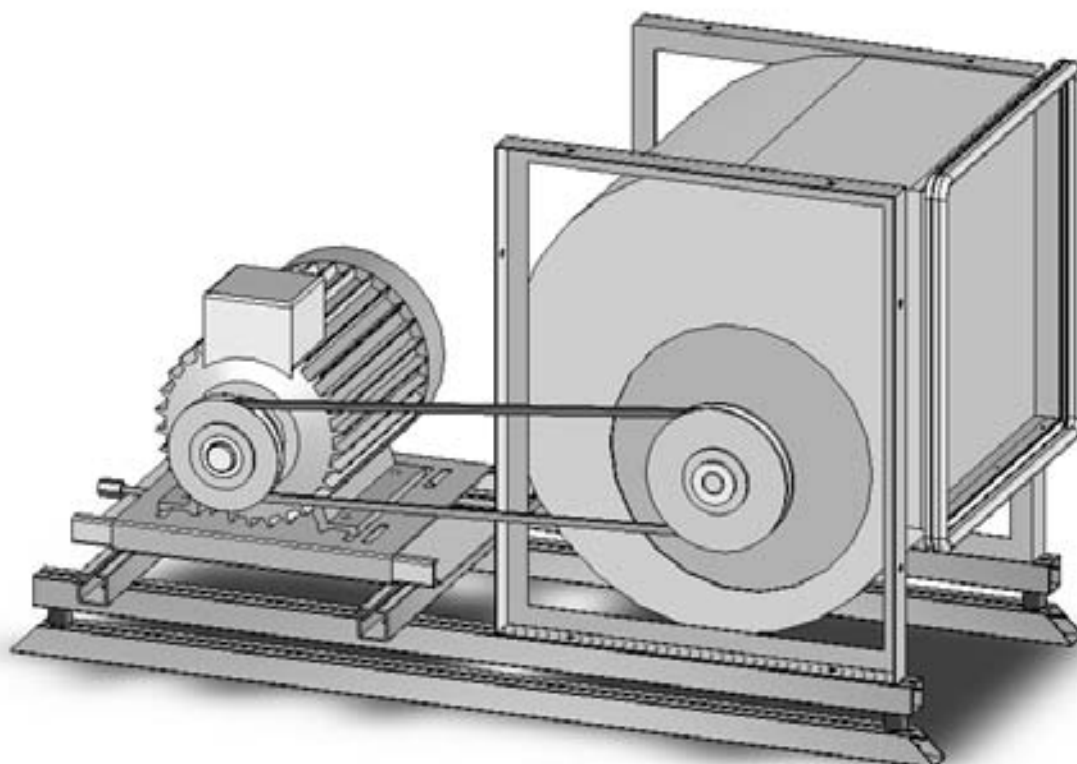

Fans

The fans are DIDW (double inlet double width) of the DIN R20 series and are available in the following versions:

- forward curved for low pressures;
- backward curved for medium to high pressures;
- Backward curved aerofoil blades for high efficiency and medium to high pressures;

All the fans are complete with frames (in the R, K, K1 and K2 types according to the operating pressure).

For some sizes of the low profile 23LX series twin fans with a common shaft and single motor are installed.



For some applications where disinfection is essential, fans without scrolls are used (plug or plenum fan)

Motors

The standard electric motors are of the following type:

- Three phase asynchronous;
- Closet construction with external fan;
- Squirrel cage;
- Horizontal shaft type B3;
- IP55 protection with class F insulation;
- IEC, CEI, UNEL approved;

The following options may be supplied:

- Con Inverter integrato;
- Monofase;
- Antideflagranti;
- Con termistore;
- Con scaldiglia;



Transmissions

The transmissions are trapezoidal belts and pulleys types SPZ, SPA, SPB, SPC.

The pulleys are fixed to the fan and motor shaft by conical taper lock bushes.

Belt tension can be adjusted by means on the motor slide rail fitted below the motor.



Antivibration mounts

Fans up to size 400 are mounted on rubber antivibration mounts and all other sizes are fitted with spring mounts.

The graph shows the vibration transmission (or rather the ratio between the applied and transmitted force) at the various frequencies (fan speeds) considering different static deflections of the antivibration mount (from 3 to 25 mm).

The static deflections depend on the weight of the fan and motor set and the number and type of mounts used which are calculated as follows:

$$x = F * k$$

where:

x = static deflection (mm)

F = applied force (kg)

k = elastic characteristic

The antivibration mounts are calculated to produce the maximum deflection possible without exceeding the F_{max} value of the antivibration mount.

The fans with rubber antivibration mounts are isolated from the front panel with a rubber connection. The fans equipped with spring mounts have a flexible connection in cloth.



Type		K (N/mm)	Max Fmax (N)
Rubber	2025-43Sh	3.5	177
Rubber	3025-43Sh	8.7	412
Rubber	4030-43Sh	12.8	706
Spring	MW 04	9.8	353
Spring	MW 05	15.7	579
Spring	MW 06	20.6	657
Spring	MW 08	27.5	873
Spring	MW 09	38.3	1216
Spring	MW 12	49.1	1570
Spring	MV 20	73.6	1982
Spring	MV 22	94.2	2541
Spring	MV 30	115.8	3630
Spring	MV 301	147.2	4120
Spring	MV 31	176.6	4944

Transmissibility

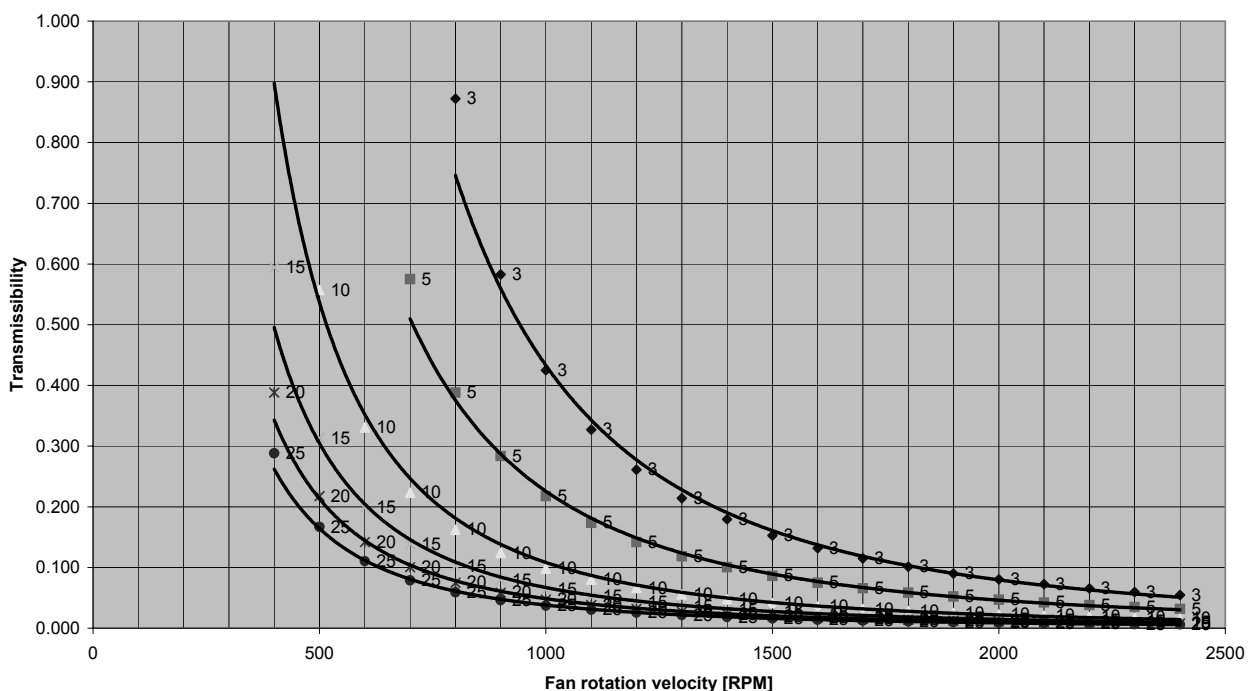

Fan diameter



23LX	Centrifugal fan											
	Fan Ø	Twin	A/V Ø	Fan Ø	Twin	A/V Ø	Fan Ø	Twin	A/V Ø	Fan Ø	Twin	A/V Ø
0304	160		Rubber	180		Rubber						Rubber
0404	160		Rubber	180		Rubber	200		Rubber	225		Rubber
0405	180		Rubber	200		Rubber	225		Rubber	250		Rubber
0406	180		Rubber	200		Rubber	225		Rubber	250		
0407	225		Rubber	250		Rubber	250	•	Rubber			
0408	250		Rubber	225	•	Rubber		•				
0409	225	•	Rubber	250	•	Rubber						
0410	225	•	Rubber	250	•	Rubber						
0411	225	•	Rubber	250	•	Rubber						
0412	250	•	Rubber									
0413	250	•	Rubber									
0505	225		Rubber	250		Rubber	280		Rubber	315		Rubber
0506	225		Rubber	250		Rubber	280		Rubber	315		Rubber
0507	250		Rubber	280		Rubber	315		Rubber			
0508	280		Rubber	315		Rubber						
0509	315		Rubber	250	•	Rubber						
0510	315		Rubber	250	•	Rubber	280	•	Rubber			
0511	250	•	Rubber	280	•	Rubber	315	•	Rubber			
0512	280	•	Rubber	315	•	Rubber						
0513	280	•	Rubber	315	•	Rubber						
0608	315		Rubber	355		Rubber	400		Rubber			
0612	355		Rubber	400		Rubber	315	•	Rubber			
0613	400		Rubber	315	•	Rubber	355	•	Rubber			
0708	355		Rubber	400		Rubber	450		Spring			
0712	400		Rubber	450		Spring	400	•	Rubber			
0713	400		Rubber	450		Spring	400	•	Rubber			
0808	355		Rubber	400		Spring	450		Spring	500		Spring
0809	400		Rubber	450		Spring	500		Spring	560		Spring
0810	400		Rubber	450		Spring	500		Spring	560		Spring
0811	400		Rubber	450		Spring	500		Spring	560		Spring
0812	450		Spring	500		Spring	560		Spring			
0813	450		Spring	500		Spring	560		Spring			
1012	500		Spring	560		Spring	630		Spring			
1013	500		Spring	560		Spring	630		Spring	710		Spring
1212	500		Spring	560		Spring	630		Spring	710		Spring
1213	560		Spring	630		Spring	710		Spring			
1214	560		Spring	630		Spring	710		Spring			
1216	630		Spring	710		Spring	800		Spring	900		Spring
1220	710		Spring	800		Spring	900		Spring			
1224	800		Spring	900		Spring						
1416	710		Spring	800		Spring	900		Spring			
1420	800		Spring	900		Spring	100		Spring			
1424	900		Spring	1000		Spring						
1428	900		Spring	1000		Spring						

Fan diameter



23LX	Double fans (running and stand-by)		Plug fan		
	Fan diameter	Antivibration mount	Fan diameter	Antivibration mount	Fan quantity
0304	180	RUBBER	250	RUBBER	1
0404	225	RUBBER	280	RUBBER	1
0405	250	RUBBER	280	RUBBER	1
0406	250	RUBBER	315	RUBBER	1
0407	-	-	355	RUBBER	1
0408	-	-	355	RUBBER	1
0409	-	-	315	RUBBER	2
0410	-	-	315	RUBBER	2
0411	-	-	355	E	2
0412	-	-	355	RUBBER	2
0413	-	-	355	RUBBER	2
0505	280	RUBBER	315	RUBBER	1
0506	315	RUBBER	355	RUBBER	1
0507	315	RUBBER	400	RUBBER	1
0508	315	RUBBER	450	SPRING	1
0509	-	-	450	SPRING	1
0510	-	-	355	RUBBER	2
0511	-	-	355	RUBBER	2
0512	-	-	355	RUBBER	2
0513	-	-	400	RUBBER	2
0608	400	RUBBER	450	SPRING	1
0612	-	-	400	RUBBER	2
0613	-	-	500	SPRING	2
0708	450	SPRING	500	SPRING	1
0712	-	-	450	SPRING	2
0713	-	-	500	SPRING	2
0808	500	SPRING	560	SPRING	1
0809	500	SPRING	630	SPRING	1
0810	560	SPRING	630	SPRING	1
0811	560	SPRING	710	SPRING	1
0812	560	SPRING	710	SPRING	1
0813	560	SPRING	710	SPRING	1
1012	630	SPRING	800	SPRING	1
1013	710	SPRING	800	SPRING	1
1212	710	SPRING	900	SPRING	1
1213	710	SPRING	900	SPRING	1
1214	710	SPRING	900	SPRING	1
1216	800	SPRING	1000	SPRING	1
1220	900	SPRING	800	SPRING	2
1224	900	SPRING	900	SPRING	2
1416	900	SPRING	1120	SPRING	1
1420	1000	SPRING	900	SPRING	2
1424	1000	SPRING	1000	SPRING	2
1428	1000	SPRING	1000	SPRING	2

Dimensions of externally mounted dampers

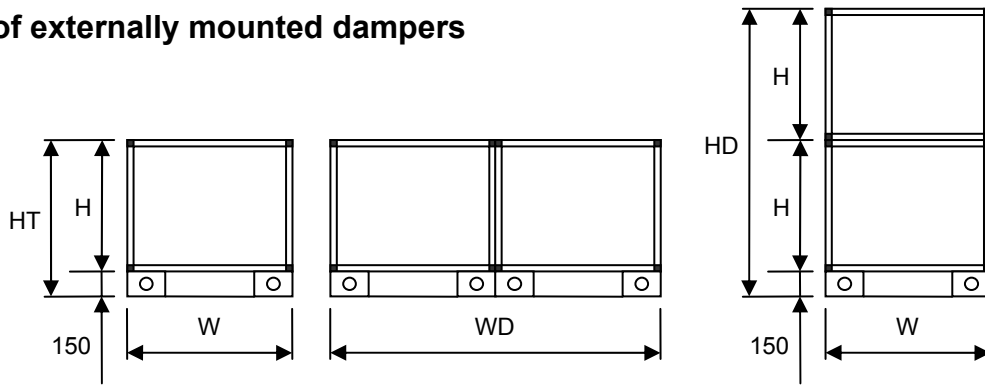

23LX	W	WD	H	HT	HD
304	710	1420	550	700	1250
404	710	1420	710	860	1570
405	870	1740	710	860	1570
406	1030	2060	710	860	1570
407	1190	2380	710	860	1570
408	1350	2700	710	860	1570
409	1510	3020	710	860	1570
410	1670	3340	710	860	1570
411	1830	3660	710	860	1570
412	1990	3980	710	860	1570
413	2150	4300	710	860	1570
505	870	1740	870	1020	1890
506	1030	2060	870	1020	1890
507	1190	2380	870	1020	1890
508	1350	2700	870	1020	1890
509	1510	3020	870	1020	1890
510	1670	3340	870	1020	1890
511	1830	3660	870	1020	1890
512	1990	3980	870	1020	1890
513	2150	4300	870	1020	1890
608	1350	2700	1030	1180	2210
612	1990	3980	1030	1180	2210
613	2150	4300	1030	1180	2210
708	1350	2700	1190	1340	2530
712	1990	3980	1190	1340	2530
713	2150	4300	1190	1340	2530
808	1350	2700	1350	1500	2850
809	1510	3020	1350	1500	2850
810	1670	3340	1350	1500	2850
811	1830	3660	1350	1500	2850
812	1990	3980	1350	1500	2850
813	2150	4300	1350	1500	2850
1012	1990	3980	1670	1820	3490
1013	2150	4300	1670	1820	3490
1212	1990	3980	1990	2140	4130
1213	2150	4300	1990	2140	4130
1214	2310	4620	1990	2140	4130
1216	2630	5260	1990	2140	4130
1220	3270	6540	1990	2140	4130
1224	3910	7820	1990	2140	4130
1416	2630	5260	2310	2460	4770
1420	3270	6540	2310	2460	4770
1424	3910	7820	2310	2460	4770
1428	4550	9100	2310	2460	4770

Typical length of the main components

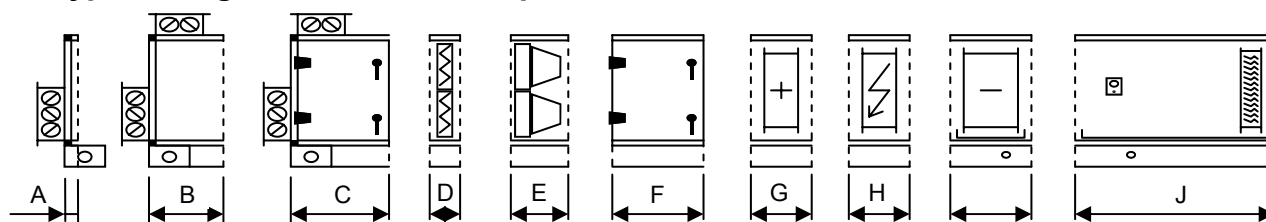

23LX	A	B	C	D	E	F	G	H	I	J
304	35	195	675	160	320	640	320	320	480	800
404	35	195	675	160	320	640	320	320	480	800
405	35	195	675	160	320	640	320	320	480	800
406	35	195	675	160	320	640	320	320	480	800
407	35	195	675	160	320	640	320	320	480	800
408	35	195	675	160	320	640	320	320	480	800
409	35	195	675	160	320	640	320	320	480	800
410	35	195	675	160	320	640	320	320	480	800
411	35	195	675	160	320	640	320	320	480	800
412	35	195	675	160	320	640	320	320	480	800
413	35	195	675	160	320	640	320	320	480	800
505	35	195	675	160	320	640	320	320	480	800
506	35	195	675	160	320	640	320	320	480	800
507	35	195	675	160	320	640	320	320	480	800
508	35	195	675	160	320	640	320	320	480	800
509	35	195	675	160	320	640	320	320	480	800
510	35	195	675	160	320	640	320	320	480	800
511	35	195	675	160	320	640	320	320	480	800
512	35	195	675	160	320	640	320	320	480	800
513	35	195	675	160	320	640	320	320	480	800
608	35	195	675	160	320	640	320	320	480	800
612	35	195	675	160	320	640	320	320	480	800
613	35	195	675	160	320	640	320	320	480	800
708	35	355	675	160	320	640	320	320	480	800
712	35	355	675	160	320	640	320	320	480	800
713	35	355	675	160	320	640	320	320	480	800
808	35	355	675	160	320	640	320	320	480	800
809	35	355	675	160	320	640	320	320	480	800
810	35	355	675	160	320	640	320	320	480	800
811	35	355	675	160	320	640	320	320	480	800
812	35	355	675	160	320	640	320	320	480	800
813	35	355	675	160	320	640	320	320	480	800
1012	35	355	675	160	320	640	320	320	480	800
1013	35	355	675	160	320	640	320	320	480	800
1212	35	355	675	160	320	640	320	320	480	800
1213	35	355	675	160	320	640	320	320	480	800
1214	35	355	675	160	320	640	320	320	480	800
1216	35	355	675	160	320	640	320	320	480	800
1220	35	355	675	160	320	640	320	320	480	800
1224	35	355	675	160	320	640	320	320	480	800
1416	35	515	675	160	320	640	320	320	480	800
1420	35	515	675	160	320	640	320	320	480	800
1424	35	515	675	160	320	640	320	320	480	800
1428	35	515	675	160	320	640	320	320	480	800

Typical length of the main components

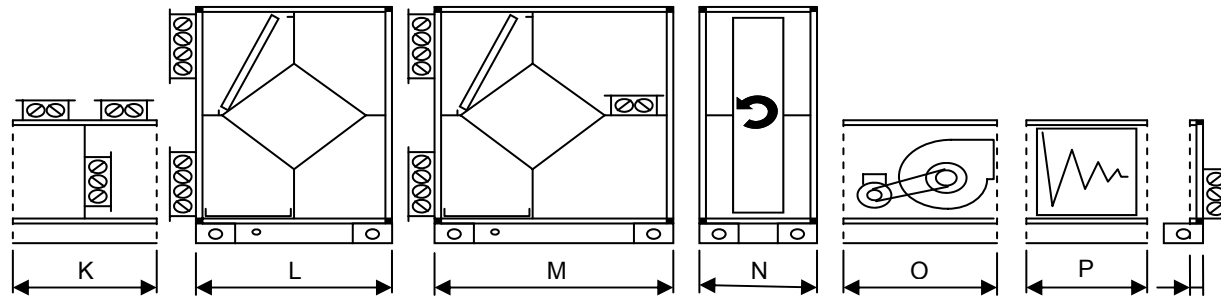

23LX	K	L	M	N	O	P	Q
304	480	870	1030	800	800	960	35
404	800	1190	1350	800	800	960	35
405	800	1190	1350	800	800	960	35
406	800	1190	1350	800	800	960	35
407	800	1190	1350	800	960	960	35
408	800	1190	1350	800	960	960	35
409	800	1190	1350	800	960	960	35
410	800	1190	1350	800	960	960	35
411	800	1190	1350	800	960	960	35
412	800	1190	1350	800	960	960	35
413	800	1190	1350	800	960	960	35
505	800	1350	1510	800	960	960	35
506	800	1350	1510	800	960	960	35
507	800	1350	1510	800	960	960	35
508	800	1350	1510	800	960	960	35
509	800	1350	1510	800	1120	960	35
510	800	1350	1510	800	1120	960	35
511	800	1350	1510	800	960	960	35
512	800	1350	1510	800	960	960	35
513	800	1350	1510	800	960	960	35
608	800	1510	1830	800	1120	960	35
612	800	1510	1830	800	1120	960	35
613	1120	1510	1830	800	1280	960	35
708	1120	1510	1830	800	1120	960	35
712	1120	1510	1830	800	1280	960	35
713	1120	1510	1830	800	1280	960	35
808	1120	1670	1830	800	1120	960	35
809	1120	1670	1830	800	1280	960	35
810	1120	1670	1830	800	1280	960	35
811	1120	1670	1830	800	1280	960	35
812	1120	1670	1830	800	1440	960	35
813	1120	1670	1830	800	1440	960	35
1012	1440	1990	2770	800	1600	960	35
1013	1440	1990	2770	800	1600	960	35
1212	1760	2150	3090	800	1600	960	35
1213	1760	2150	3090	800	1760	960	35
1214	1760	2150	3090	800	1760	960	35
1216	1760	2150	3090	800	1920	960	35
1220	1760	2150	3090	800	2080	960	35
1224	1760	2150	3090	800	2080	960	35
1416	2080	2150	3090	800	2080	960	35
1420	2080	2150	3090	800	2080	960	35
1424	2080	2150	3090	800	2080	960	35
1428	2080	2150	3090	800	2080	960	35



● **Direct Sales Offices:**

BELGIUM AND LUXEMBOURG

☎ + 32.3.633.3045

✉ info.be@lennox europe.com

FRANCE

☎ +33 1 64 76 23 23

✉ info.fr@lennox europe.com

GERMANY

☎ + 49 (0) 69 42 09 790

✉ info.de@lennox europe.com

NETHERLANDS

☎ + 31.332.471.800

✉ info.nl@lennox europe.com

POLAND

☎ +48 22 58 48 610

✉ info.pl@lennox europe.com

PORTUGAL

☎ +351 229 066 050

✉ info.pt@lennox europe.com

RUSSIA

☎ +7 495 626 56 53

✉ info.ru@lennox europe.com

SLOVAKIA

☎ +421 2 58 31 83 12

✉ info.sk@lennox europe.com

SPAIN

☎ +34 91 540 18 10

✉ info.sp@lennox europe.com

UKRAINE

☎ +380 44 461 87 79

✉ info.ua@lennox europe.com

UNITED KINGDOM AND IRELAND

☎ +44 1604 669 100

✉ info.uk@lennox europe.com

● **Distributors and Agents**

Algeria, Austria, Belarus, Botswana, Bulgaria, Cyprus, Czech Republic, Denmark, Estonia, Finland, Georgia, Greece, Hungary, Israel, Italy, Kazakhstan, Latvia, Lebanon, Lithuania, Morocco, Near East, Norway, Romania, Serbia, Slovenia, Sweden, Switzerland, Tunisia, Turkey

LENNOX DISTRIBUTION

☎ +33.4.72.23.20.00

✉ info.dist@lennox europe.com



CLEANAIR 23LX-AGU-0909-E

Due to Lennox's ongoing commitment to quality, the Specifications, Ratings and Dimensions are subject to change without notice and without incurring liability.

Improper installation, adjustment, alteration, service or maintenance can cause property damage or personal injury.

Installation and service must be performed by a qualified installer and servicing agency