

**TWIN SCREW COMPRESSOR TYPE
HITACHI WATER-COOLED CHILLERS**

NEW
H Series

HITACHI

Hitachi Appliances, Inc.

URL : <http://www.hitachi-ap.com>

Specifications in this catalogue are subject to change without notice in order that HITACHI may bring the latest innovations to their customers.

Distributed By :



The Water-cooled chiller "H series" with improved efficiency and functionality by several advanced technology.

This series with the world's best standard A-type screw compressor and newly designed shell and tube heat exchanger that have powerful cooling ability, low noise, low vibration, high efficiency and high reliability is the perfect answer to all your needs!!



Enhanced Line-up ~up to 570 HP~

Top Class High COP

High-performance A-type Screw Compressor

Highly Reliable Shell and Tube Heat Exchanger

Precise Capacity Control Technology

Excellent Control Function

Products Series



RCUG-WHYZ(-E)

Nominal Capacity Range (50Hz)

130 kW to 1,758 kW

37.0 USRT to 500.0 USRT

111,800 kcal/h to 1,512,000 kcal/h



RCU-WHYZ(-E)

Nominal Capacity Range (50Hz)

140 kW to 1,825 kW

39.8 USRT to 519.1 USRT

120,400 kcal/h to 1,569,500 kcal/h



Wide Line-up

To meet the need for air conditioning systems for large facilities and the demand for higher capacity industrial cooling systems, we have added the large screw chillers, the 410-570HP, to our product line-up.

RCUG-WHYZ(-E)

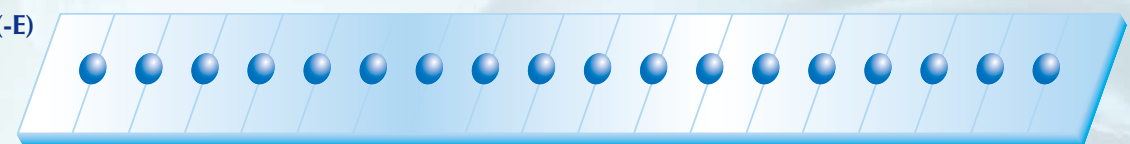

RCU-WHYZ(-E)



Technical Features

Top Class High COP

In the new model series, the power consumption is largely reduced over the current model series due to newly designed high-efficiency cooling system. Also COP is largely increased from 4.42 in the current 100HP model to 5.13 in the new 100HP model.

COP Comparison



High-performance A-type Screw Compressor ~ Newly Designed ~

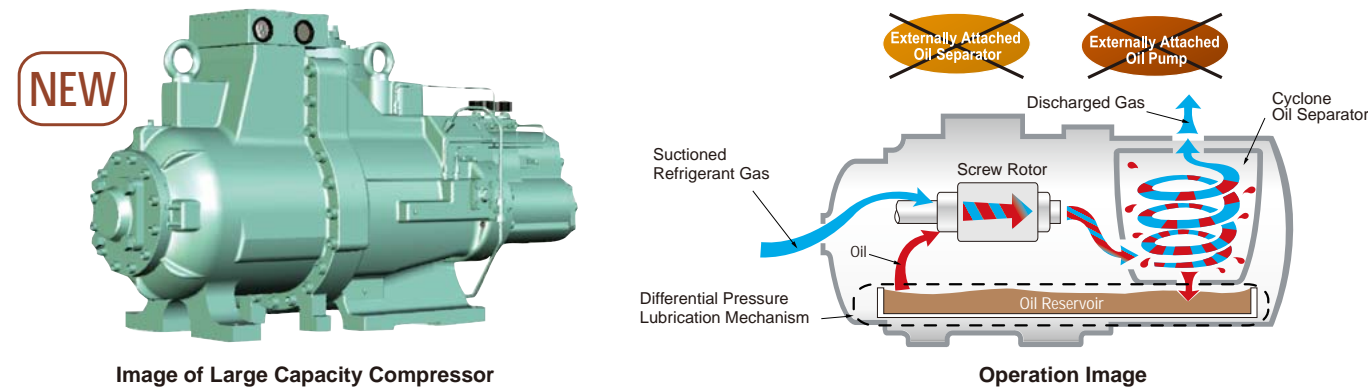

Built-in Cyclone Oil Separator

Low oil carrying-out is realized and reduction of heat transfer efficiency is minimized.

No outside pump is required due to the reliable differential-pressure oil-feeding system.

This oil-feeding system, which does not use any electrical mechanism, prevents the compressor from being damaged and maintains long-term stable operation.

High Technology by Internal Manufacture

Because all manufacturing processes, from rotor manufacturing to unit assembly, are done internally, exceptional reliability is achieved.

Low Vibration, Low Noise

Without the conventional demister chamber system, no noise is produced during oil separation of discharge gas. A vibration-proof base is not required for the chiller body thanks to the firmly-secured, low-vibration screw compressor.

Highly Reliable Shell and Tube Heat Exchanger ~ Newly Designed ~

- Simple structure and easy for maintenance
- Reduced cost and adapted to satisfy various demands
- Freeze protection thermostat and other safety devices
- Integral and reliable performance

Precise Capacity Control Technology

Continuous Capacity Control

The temperature of the chilled water outlet can be kept at the set temperature $\pm 1^\circ\text{C}$ by continuous capacity control, so it is suitable for industrial use.

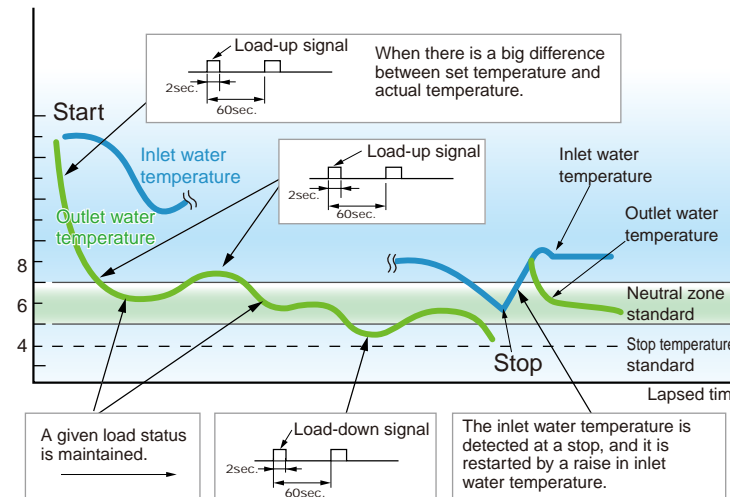

Capacity Controller Structural Outline (HITACHI Patented System)

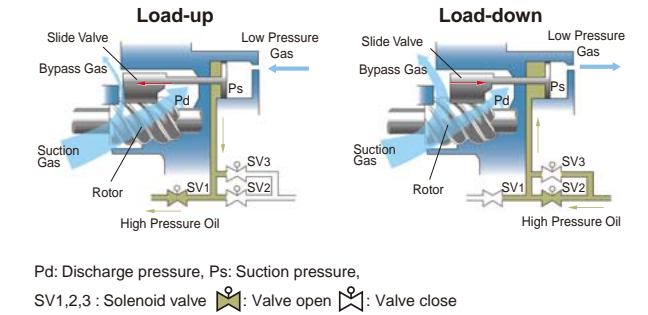

Excellent Control Function

Liquid Crystal Screen Display (Optional Accessory)

- Big colorful liquid crystal display
- Man-machine conversation screen, display content completely.
- Show data at real time
- Time starting function
- Leave message board (for shift)
- Communication adapter provides Communication with RS485 physics connection to BMS.



Building Management System (BMS)

Hitachi uses Building Management System through LONWORKS[®]. For chiller air-conditioning, Hitachi provides its own central station system. No complicated work is necessary.

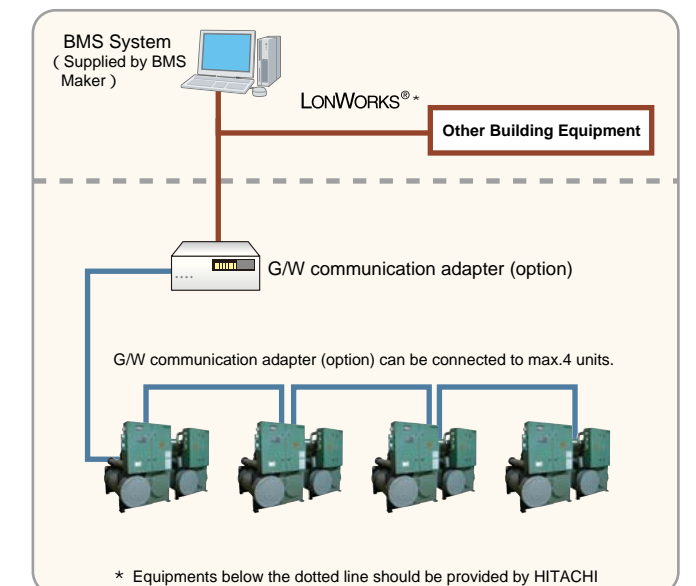
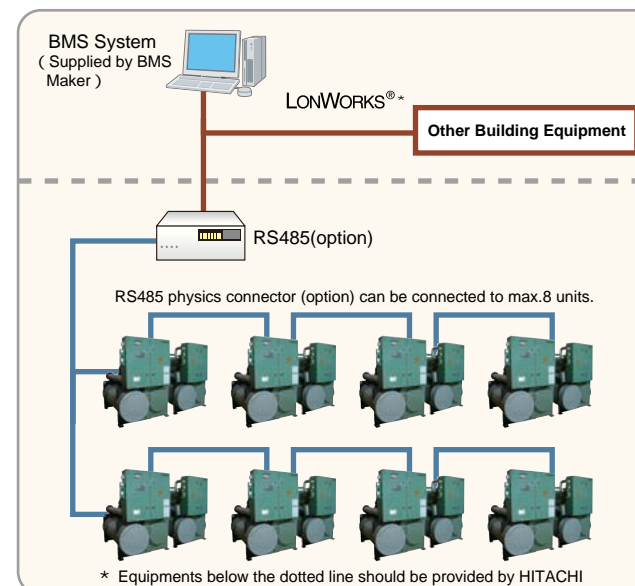

* : LONWORKS[®] are trademarks of Echelon Corporation registered in the United States and other countries.

R407C General Data



Model	Standard Liquid Crystal Display	RCUG40WHYZ	RCUG50WHYZ	RCUG60WHYZ	RCUG80WHYZ	RCUG100WHYZ	RCUG120WHYZ	RCUG150WHYZ	RCUG180WHYZ	RCUG220WHYZ	RCUG260WHYZ	
		RCUG40WHYZ-E	RCUG50WHYZ-E	RCUG60WHYZ-E	RCUG80WHYZ-E	RCUG100WHYZ-E	RCUG120WHYZ-E	RCUG150WHYZ-E	RCUG180WHYZ-E	RCUG220WHYZ-E	RCUG260WHYZ-E	
Power Source		Main (AC 3) 380, 415V / 50Hz, Control (AC 1) 220, 240V / 50Hz				Main (AC 3) 380, 415V / 50Hz, Control (AC 1) 220, 240V / 50Hz						
Nominal Cooling Capacity	kW	130	162	197	260	323	392	485	589	688	820	
	USRT	37.0	46.1	56.0	74.4	91.8	111.5	137.9	167.5	195.6	233.2	
	kcal/h	111,800	139,320	169,420	223,600	277,780	337,120	417,100	506,540	591,680	705,200	
Condenser Water Flow Rate	m³/h	27.5	34.2	41.5	54.9	68.1	82.6	102.3	124.1	143.4	171.0	
Chilled Water Flow Rate	m³/h	22.4	27.9	33.9	44.7	55.6	67.4	83.4	101.3	118.3	141.0	
Capacity Control		Continuous Capacity Control				Continuous Capacity Control						
Outer Dimensions	%	100~15, 0			100~7.5, 0			100~7.5, 0			100~7.5, 0	
	Height	1,506			1,495			1,685			1,810	
	Width	1,764			2,759			3,170			2,622	
Net Weight	mm	910			1,070			1,220			1,922	
	kg	878	1,000	1,032	1,798	2,053	2,165	3,570	3,748	5,204	5,420	
Refrigerant		R407C				R407C						
Flow Control		Electronic Expansion Valve				Electronic Expansion Valve						
Number of Circuits		1				2		3			2	
Compressor		Semi-Hermetic Screw Type				Semi-Hermetic Screw Type						
Type		40ASCCW-Z	50ASCCW-Z	60ASCCW-Z	40ASCCW-Z	50ASCCW-Z	60ASCCW-Z	50ASCCW-Z	60ASCCW-Z	100ASCCW-Z	100ASCCW-Z, 130ASCCW-Z	
Model												
Quantity		1				2		3			2	
Condenser		Shell-and-Tube Type				Shell-and-Tube Type						
Water Cooler		Shell-and-Tube, Dry Expansion Type				Shell-and-Tube, Dry Expansion Type						
Safety Devices		Three-Phase Overcurrent Relay, High-Pressure Switch, Low-Pressure Switch, Oil Heater, Internal Thermostat for Compressor Motor, Fusible Plug, Freeze Protection Thermostat, Reverse Phase Protection Relay, Discharge Gas Thermostat, Operation Hour-Meter and Pressure Relief Valve				Three-Phase Overcurrent Relay, High-Pressure Switch, Low-Pressure Switch, Oil Heater, Internal Thermostat for Compressor Motor, Fusible Plug, Freeze Protection Thermostat, Reverse Phase Protection Relay, Discharge Gas Thermostat, Operation Hour-Meter and Pressure Relief Valve						
Shipping Dimensions	Height	1,747			1,765			1,765			2,239	
	Width	1,898			2,960			2,960			3,320	
	Depth	1,106			1,250			1,250			1,358	
Shipping Weight	kg	999	1,121	1,153	1,978	2,233	2,345	3,851	4,029	5,876	6,092	
Piping Connections for Condenser	Inlet	With 78 Inner Diametre Companion Flange				4		4			With 142 Inner Diametre Companion Flange	
Piping Connections for Water Cooler	Outlet					4		4			With 116 Inner Diametre Companion Flange	
	Inlet	3	3	3	With 142 Inner Diametre Companion Flange	With 142 Inner Diametre Companion Flange						
Piping Connections for Water Cooler	Outlet	3	3	3	Companion Flange							

Model	Standard Liquid Crystal Display	RCUG300WHYZ	RCUG340WHYZ	RCUG380WHYZ	RCUG410WHYZ	RCUG450WHYZ	RCUG490WHYZ	RCUG530WHYZ	RCUG570WHYZ	
		RCUG300WHYZ-E	RCUG340WHYZ-E	RCUG380WHYZ-E	RCUG410WHYZ-E	RCUG450WHYZ-E	RCUG490WHYZ-E	RCUG530WHYZ-E	RCUG570WHYZ-E	
Power Source		Main (AC 3) 380, 415V / 50Hz, Control (AC 1) 220, 240V / 50Hz				Main (AC 3) 380, 415V / 50Hz, Control (AC 1) 220, 240V / 50Hz				
Nominal Cooling Capacity	kW	952	1,061	1,170	1,296	1,428	1,537	1,646	1,758	
	USRT	270.7	301.7	332.7	368.5	406.0	437.0	468.0	500.0	
	kcal/h	818,720	912,460	1,006,200	1,114,560	1,228,080	1,321,820	1,415,560	1,512,000	
Condenser Water Flow Rate	m³/h	198.4	221.0	243.6	270.2	297.6	320.2	342.9	366.0	
Chilled Water Flow Rate	m³/h	163.7	182.5	201.2	222.9	245.6	264.3	283.1	302.4	
Capacity Control		Continuous Capacity Control				Continuous Capacity Control				
Outer Dimensions	%	100~7.5, 0			100~5, 0			100~5, 0		
	Height	1,879			1,879			1,879		
	Width	2,622			3,983			3,983		
Net Weight	mm	1,922			1,922			1,922		
	kg	5,638	5,851	6,064	8,239	8,457	8,670	8,883	9,096	
Refrigerant		R407C				R407C				
Flow Control		Electronic Expansion Valve				Electronic Expansion Valve				
Number of Circuits		2				3		3		
Compressor		Semi-Hermetic Screw Type				Semi-Hermetic Screw Type				
Type		130ASCCW-Z	130ASCCW-Z, 170ASCCW-Z	170ASCCW-Z	100ASCCW-Z, 130ASCCW-Z	130ASCCW-Z	130ASCCW-Z, 170ASCCW-Z	130ASCCW-Z, 170ASCCW-Z	170ASCCW-Z	
Model										
Quantity		2				3		3		
Condenser		Shell-and-Tube Type				Shell-and-Tube Type				
Water Cooler		Shell-and-Tube, Dry Expansion Type				Shell-and-Tube, Dry Expansion Type				
Safety Devices		Three-Phase Overcurrent Relay, High-Pressure Switch, Low-Pressure Switch, Oil Heater, Internal Thermostat for Compressor Motor, Fusible Plug, Freeze Protection Thermostat, Reverse Phase Protection Relay, Discharge Gas Thermostat, Operation Hour-Meter and Pressure Relief Valve				Three-Phase Overcurrent Relay, High-Pressure Switch, Low-Pressure Switch, Oil Heater, Internal Thermostat for Compressor Motor, Fusible Plug, Freeze Protection Thermostat, Reverse Phase Protection Relay, Discharge Gas Thermostat, Operation Hour-Meter and Pressure Relief Valve				
Shipping Dimensions	Height	2,239			2,239			2,239		
	Width	1,464 x 2 Modules			1,464 x 3 Modules			1,464 x 3 Modules		
	Depth	2,247			2,247			2,247		
Shipping Weight	kg	6,310	6,523	6,736	9,247	9,465	9,678	9,891	10,104	
Piping Connections for Condenser	Inlet	With 116 Inner Diametre Companion Flange				With 116 Inner Diametre Companion Flange				
Piping Connections for Water Cooler	Outlet									
	Inlet	With 142 Inner Diametre Companion Flange				With 142 Inner Diametre Companion Flange				
Piping Connections for Water Cooler	Outlet									

- NOTES:**
- The nominal cooling capacities are based on the following conditions.
Chilled Water Inlet / Outlet Temperature: 12°C / 7°C
Condenser Water Inlet / Outlet Temperature: 30°C / 35°C
 - Working Range
Condenser Water Outlet Temperature: 22°C to 37°C
Condenser Water Temperature Difference: 3.5°C to 10°C
Chilled Water Outlet Temperature: 5°C to 20°C
Chilled Water Temperature Difference: 2.5°C to 10°C
 - Communication adapter connecting the unit to BMS (Building Management System) is an optional accessory, please contact with HITACHI or HITACHI distributor if required.
 - The unit with liquid crystal display differs from the unit with segment code display in electric box, however, both have the same outer dimensions.

Model	Standard Liquid Crystal Display	RCU40WHYZ	RCU50WHYZ	RCU60WHYZ	RCU80WHYZ	RCU100WHYZ	RCU120WHYZ	RCU150WHYZ	RCU180WHYZ	RCU220WHYZ	RCU260WHYZ	
		RCU40WHYZ-E	RCU50WHYZ-E	RCU60WHYZ-E	RCU80WHYZ-E	RCU100WHYZ-E	RCU120WHYZ-E	RCU150WHYZ-E	RCU180WHYZ-E	RCU220WHYZ-E	RCU260WHYZ-E	
Power Source		Main (AC 3) 380, 415V / 50Hz, Control (AC 1) 220, 240V / 50Hz					Main (AC 3) 380, 415V / 50Hz, Control (AC 1) 220, 240V / 50Hz					
Nominal Cooling Capacity	kW	140	172	213	279	344	425	516	637	713	842	
	USRT	39.8	48.9	60.6	79.3	97.8	120.8	146.7	181.1	202.7	239.5	
	kcal/h	120,400	147,920	183,180	239,940	295,840	365,500	443,760	547,820	613,180	724,120	
Condenser Water Flow Rate	m ³ /h	28.6	35.3	44.0	57.3	70.7	87.4	106.1	130.9	146.2	172.7	
Chilled Water Flow Rate	m ³ /h	24.0	59.2	37.0	48.0	59.2	73.1	88.7	109.5	122.6	144.8	
Capacity Control		Continuous Capacity Control					Continuous Capacity Control					
		100~15, 0			100~7.5, 0		100~7.5, 0		100~5, 0		100~7.5, 0	
Outer Dimensions	Height	1,506			1,495		1,495		1,685		1,810	
	Width	1,764			2,759		2,759		3,170		2,622	
	Depth	910			1,070		1,070		1,220		1,922	
Net Weight	kg	878	1,000	1,032	1,798	2,053	2,165	3,570	3,748	5,204	5,420	
Refrigerant		R22					R22					
Flow Control		Electronic Expansion Valve					Electronic Expansion Valve					
Number of Circuits		1			2		2		3		2	
Compressor		Semi-Hermetic Screw Type					Semi-Hermetic Screw Type					
Model		40ASCCW-Z	50ASCCW-Z	60ASCCW-Z	40ASCCW-Z	50ASCCW-Z	60ASCCW-Z	50ASCCW-Z	60ASCCW-Z	100ASCCW-Z	100ASCCW-Z, 130ASCCW-Z	
Quantity		1			2		2		3		2	
Condenser		Shell-and-Tube Type					Shell-and-Tube Type					
Water Cooler		Shell-and-Tube, Dry Expansion Type					Shell-and-Tube, Dry Expansion Type					
Safety Devices		Three-Phase Overcurrent Relay, High-Pressure Switch, Low-Pressure Switch, Oil Heater, Internal Thermostat for Compressor Motor, Fusible Plug, Freeze Protection Thermostat, Reverse Phase Protection Relay, Discharge Gas Thermostat, Operation Hour-Meter and Pressure Relief Valve					Three-Phase Overcurrent Relay, High-Pressure Switch, Low-Pressure Switch, Oil Heater, Internal Thermostat for Compressor Motor, Fusible Plug, Freeze Protection Thermostat, Reverse Phase Protection Relay, Discharge Gas Thermostat, Operation Hour-Meter and Pressure Relief Valve					
Shipping Dimensions	Height	1,747			1,765		1,765		1,998		2,239	
	Width	1,898			2,960		2,960		3,320		1,464 x 2 Modules	
	Depth	1,106			1,250		1,250		1,358		2,247	
Shipping Weight	kg	999	1,121	1,153	1,978	2,233	2,345	3,851	4,029	5,874	6,092	
Piping Connections for Condenser	Inlet Outlet	With 78 Inner Diametre Companion Flange			4 4		4 4		With 142 Inner Diametre Companion Flange		With 116 Inner Diametre Companion Flange	
Piping Connections for Water Cooler	Inlet Outlet	3 3	3 3	3 3	With 142 Inner Diametre Companion Flange	With 142 Inner Diametre Companion Flange						

Model	Standard Liquid Crystal Display	RCU300WHYZ	RCU340WHYZ	RCU380WHYZ	RCU410WHYZ	RCU450WHYZ	RCU490WHYZ	RCU530WHYZ	RCU570WHYZ	
		RCU300WHYZ-E	RCU340WHYZ-E	RCU380WHYZ-E	RCU410WHYZ-E	RCU450WHYZ-E	RCU490WHYZ-E	RCU530WHYZ-E	RCU570WHYZ-E	
Power Source		Main (AC 3) 380, 415V / 50Hz, Control (AC 1) 220, 240V / 50Hz					Main (AC 3) 380, 415V / 50Hz, Control (AC 1) 220, 240V / 50Hz			
Nominal Cooling Capacity	kW	971	1,094	1,217	1,328	1,457	1,579	1,703	1,825	
	USRT	276.1	311.1	346.0	377.7	414.2	449.0	484.0	519.1	
	kcal/h	835,060	940,840	1,046,620	1,141,650	1,253,020	1,357,940	1,464,580	1,569,500	
Condenser Water Flow Rate	m ³ /h	199.1	224.4	249.5	272.4	298.7	323.8	349.3	374.2	
Chilled Water Flow Rate	m ³ /h	167.0	188.1	209.3	228.4	250.6	271.5	292.9	313.8	
Capacity Control		Continuous Capacity Control					Continuous Capacity Control			
		100~7.5, 0			100~5, 0		100~5, 0			
Outer Dimensions	Height	1,879			1,879		1,879			
	Width	2,622			3,983		3,983			
	Depth	1,922			1,922		1,922			
Net Weight	kg	5,638	5,851	6,064	8,239	8,457	8,670	8,883	9,096	
Refrigerant		R22					R22			
Flow Control		Electronic Expansion Valve					Electronic Expansion Valve			
Number of Circuits		2			3		3			
Compressor		Semi-Hermetic Screw Type					Semi-Hermetic Screw Type			
Model		130ASCCW-Z	130ASCCW-Z, 170ASCCW-Z	170ASCCW-Z	100ASCCW-Z, 130ASCCW-Z	130ASCCW-Z	130ASCCW-Z, 170ASCCW-Z	130ASCCW-Z, 170ASCCW-Z	170ASCCW-Z	
Quantity		2			3		3			
Condenser		Shell-and-Tube Type					Shell-and-Tube Type			
Water Cooler		Shell-and-Tube, Dry Expansion Type					Shell-and-Tube, Dry Expansion Type			
Safety Devices		Three-Phase Overcurrent Relay, High-Pressure Switch, Low-Pressure Switch, Oil Heater, Internal Thermostat for Compressor Motor, Fusible Plug, Freeze Protection Thermostat, Reverse Phase Protection Relay, Discharge Gas Thermostat, Operation Hour-Meter and Pressure Relief Valve					Three-Phase Overcurrent Relay, High-Pressure Switch, Low-Pressure Switch, Oil Heater, Internal Thermostat for Compressor Motor, Fusible Plug, Freeze Protection Thermostat, Reverse Phase Protection Relay, Discharge Gas Thermostat, Operation Hour-Meter and Pressure Relief Valve			
Shipping Dimensions	Height	2,239			2,239		2,239			
	Width	1,464 x 2 Modules			1,464 x 3 Modules		1,464 x 3 Modules			
	Depth	2,247			2,247		2,247			
Shipping Weight	kg	6,310	6,523	6,736	9,247	9,465	9,678	9,891	10,104	
Piping Connections for Condenser	Inlet Outlet	With 116 Inner Diametre Companion Flange					With 116 Inner Diametre Companion Flange			
Piping Connections for Water Cooler	Inlet Outlet	With 142 Inner Diametre Companion Flange					With 142 Inner Diametre Companion Flange			

- NOTES:**
- The nominal cooling capacities are based on the following conditions.
Chilled Water Inlet / Outlet Temperature: 12°C / 7°C
Condenser Water Inlet / Outlet Temperature: 30°C / 35°C
 - Working Range
Condenser Water Outlet Temperature: 22°C to 40°C
Condenser Water Temperature Difference: 3.5°C to 10°C
Chilled Water Outlet Temperature: 5°C to 20°C
Chilled Water Temperature Difference: 2.5°C to 10°C
 - Communication adapter connecting the unit to BMS (Building Management System) is an optional accessory, please contact with HITACHI or HITACHI distributor if required.
 - The unit with liquid crystal display differs from the unit with segment code display in electric box, however, both have the same outer dimensions.

Dimensional Data

R407C RCUG40, 50 and 60WHYZ(-E)

R22 RCU40, 50 and 60WHYZ(-E)

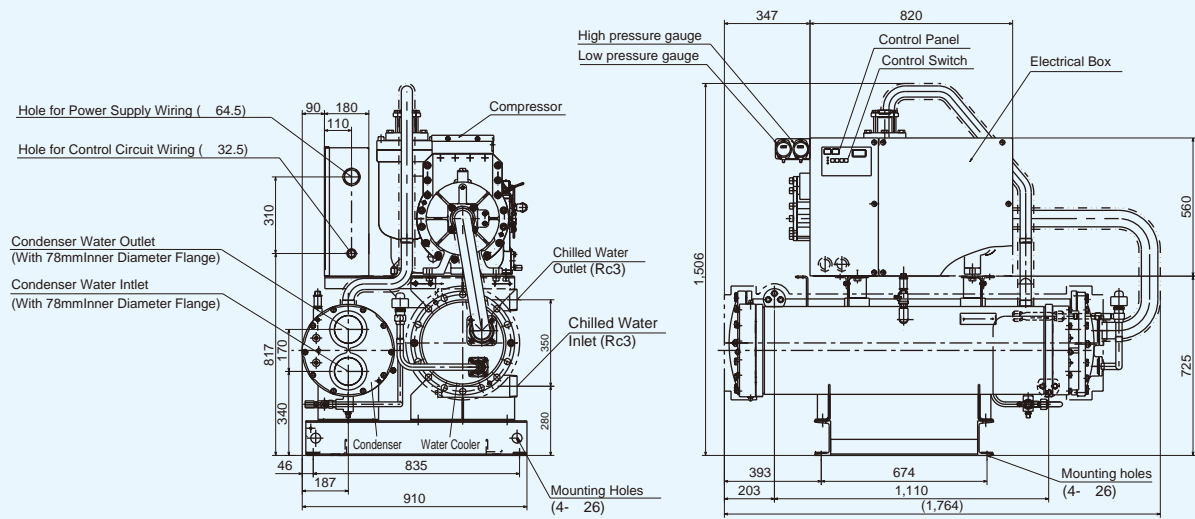

R407C RCUG220WHYZ(-E)

R22 RCU220WHYZ(-E)

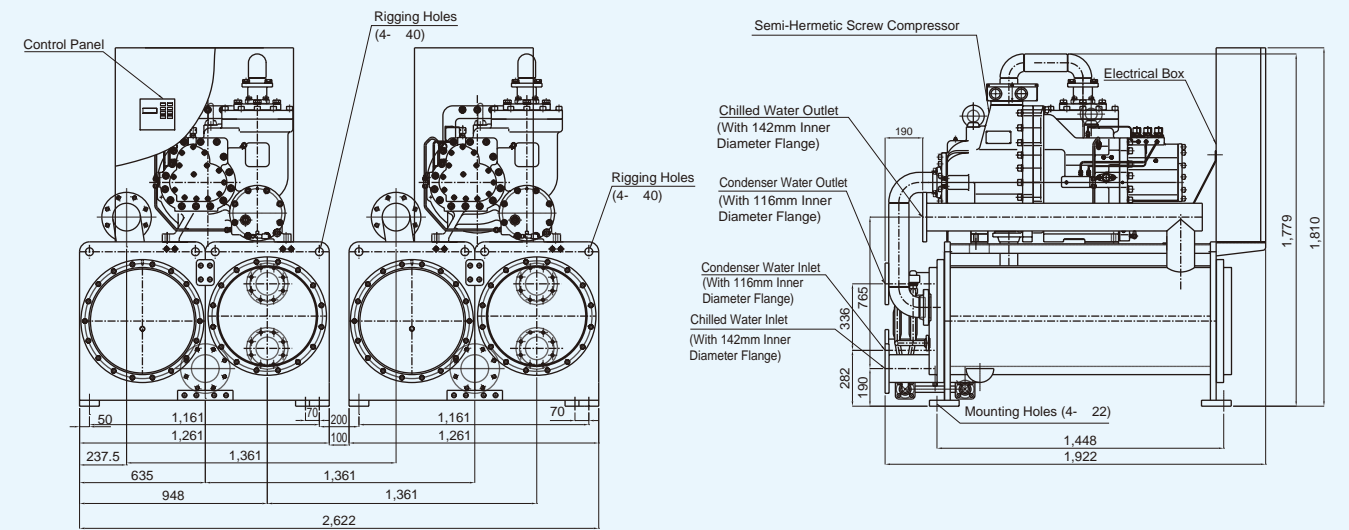

R407C RCUG80, 100 and 120WHYZ(-E)

R22 RCU80, 100 and 120WHYZ(-E)

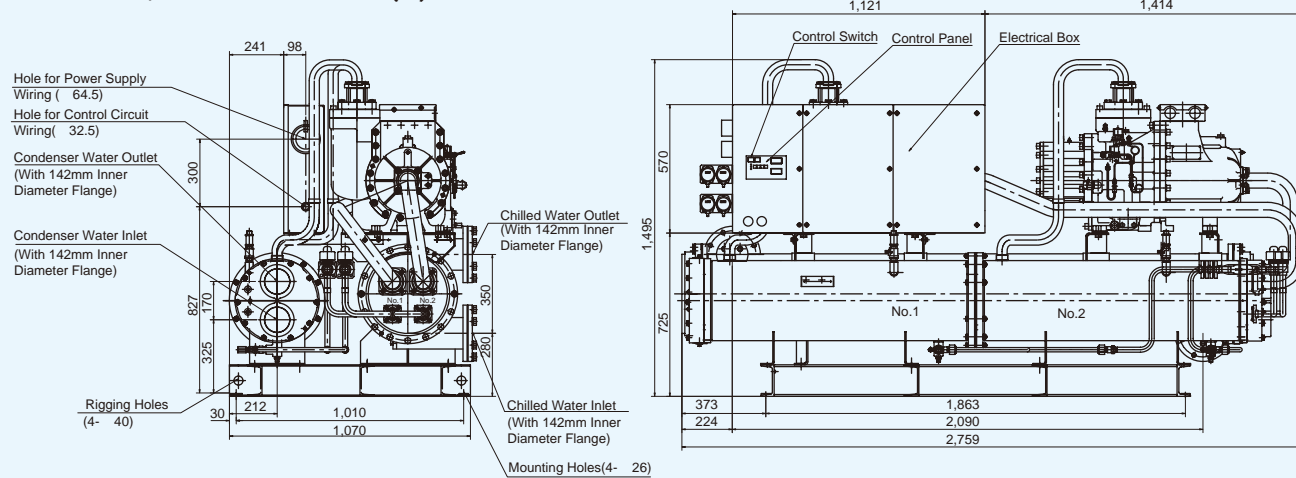

NOTE:
The unit with the refrigerant R22 differs from the unit with refrigerant R407C in the location of the discharged tube, however, both have the same outer dimensions.

R407C RCUG260, 300, 340 and 380WHYZ(-E)

R22 RCU260, 300, 340 and 380WHYZ(-E)

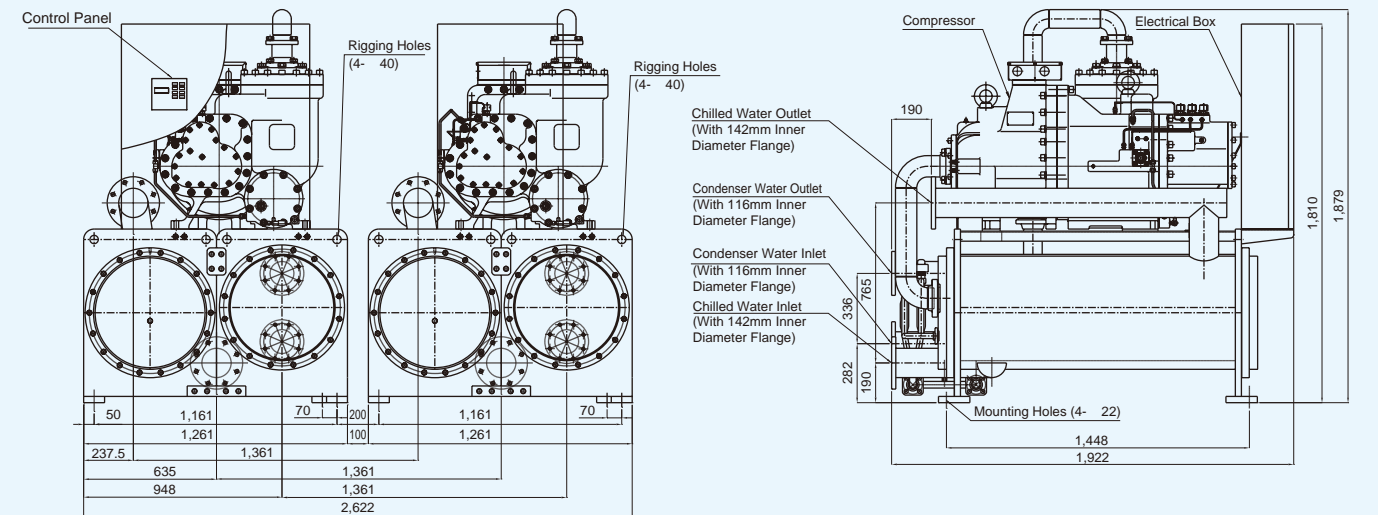

R407C RCUG150 and 180WHYZ(-E)

R22 RCU150 and 180WHYZ(-E)

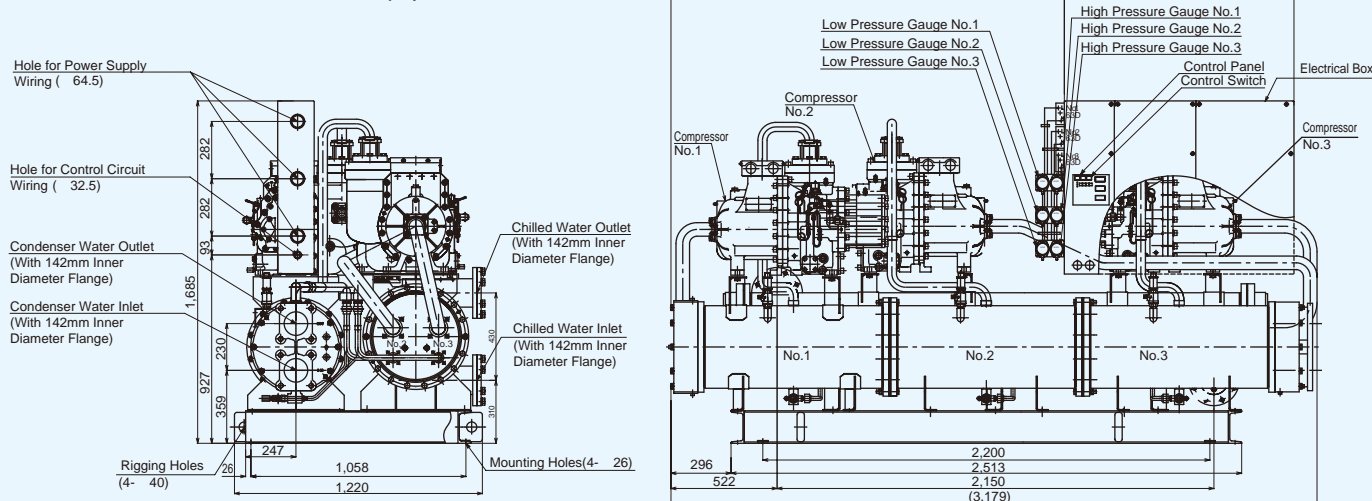

R407C RCUG410, 450, 490, 530 and 570WHYZ(-E)

R22 RCU410, 450, 490, 530 and 570WHYZ(-E)

