

**HITACHI**  
Inspire the Next

**TWIN SCREW COMPRESSOR TYPE  
HITACHI AIR-COOLED CHILLERS**

**NEW**  
**H Series**



**HITACHI**  
Hitachi Appliances, Inc.

URL : <http://www.hitachi-ap.com>  
Specifications in this catalogue are subject to change without notice in order that HITACHI may bring the latest innovations to their customers.

Distributed By :





# Technical Features

## High-performance A-type Screw Compressor ~ Newly Designed ~

NEW

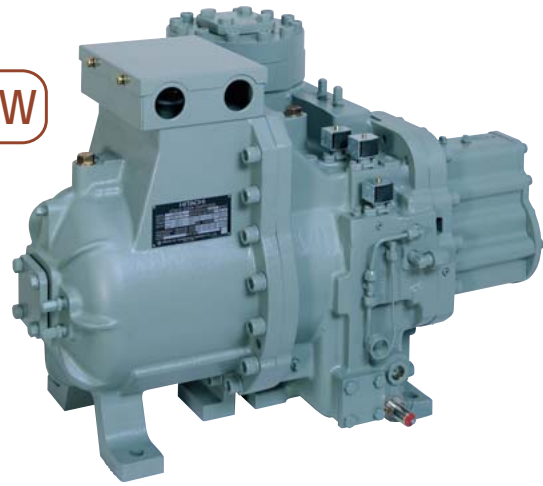

### Built-in Cyclone Oil Separator

Low oil carrying-out is realized and reduction of heat transfer efficiency is minimized.

### High Technology by Internal Manufacture

Because all manufacturing processes, from rotor manufacturing to unit assembly, are done internally, exceptional reliability is achieved.

### New Screw Compressor Operation Image

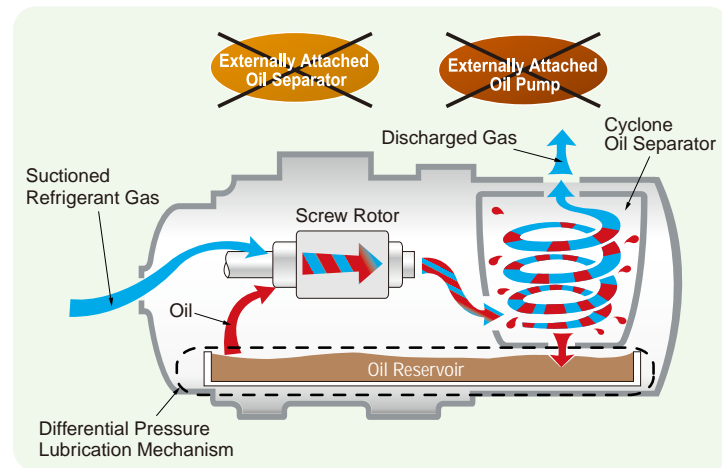

No outside pump is required due to the reliable differential-pressure oil-feeding system.

This oil-feeding system, which does not use any electrical mechanism, prevents the compressor from being damaged and maintains long-term stable operation.

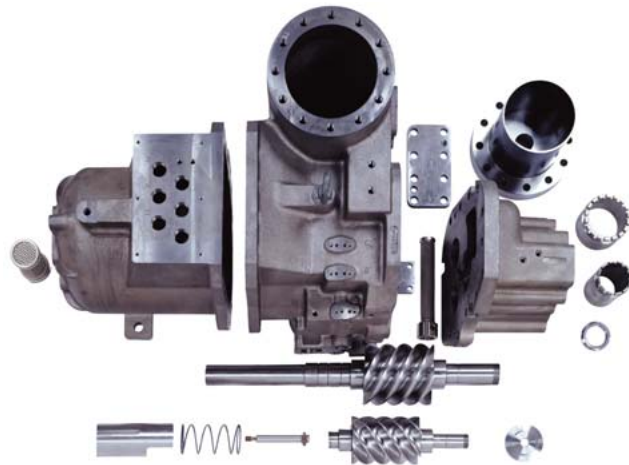

### Simple Structure with a Small Number of Parts

Whereas the number of main parts for the casing, compression mechanism and capacity control mechanism of a reciprocating compressor is **268**, that of a screw compressor is only **27**, just one tenth of the number! A structure with so few parts offers high reliability and easy maintenance.

### Vibration Comparison

Type	Reciprocating	Screw
Comp. speed (rpm) 50/60Hz	1,430 / 1,720	<b>2,880 / 3,470</b>
Full amplitude	At leg of comp.	<b>5-8</b>
	At base frame	<b>Less than 10</b>
Vib. frequency	At leg of comp.	<b>48.5 / 57.8</b>
	At base frame	<b>48 / 57.8</b>
Acceleration energy	Screw: 1/5 of reciprocating type	

### Low Vibration Level

No exclusive vibration control equipment is necessary by using low-vibration screw compressor.

## Precise Capacity Control Technology

### Continuous Capacity Control

The temperature of the chilled water outlet can be kept at the set temperature  $\pm 1^\circ\text{C}$  by continuous capacity control, so it is suitable for industrial use.

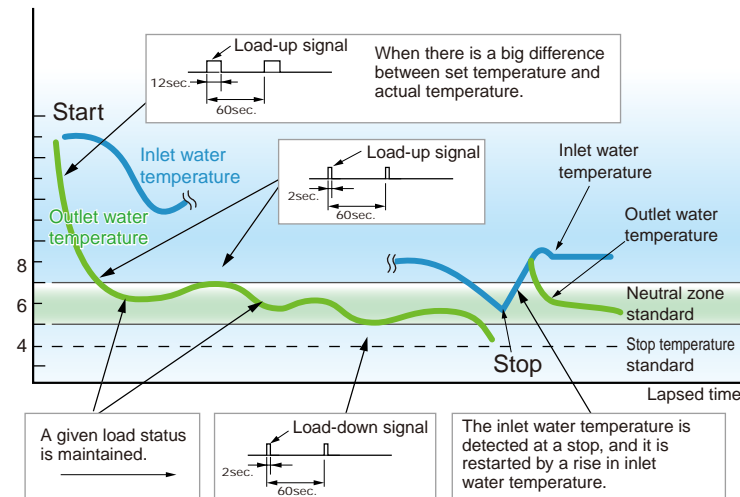

### Capacity Controller Structural Outline (HITACHI Patented System)

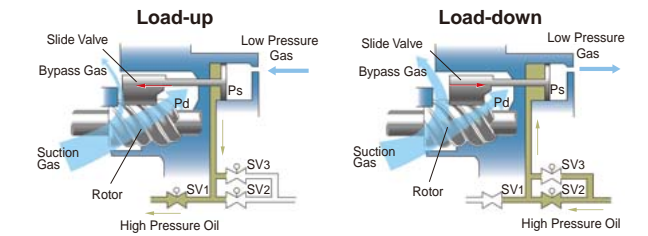

Pd: Discharge pressure, Ps: Suction pressure, SV1,2,3: Solenoid valve, : Valve open, : Valve close

## Excellent Control Function

### Building Management System (BMS)

Hitachi uses Building Management System through LONWORKS®. For chiller air-conditioning, Hitachi provides its own central station system. No complicated work is necessary.

\* : "LONWORKS®" is a trademark of Echelon Corporation registered in the United States and other countries.

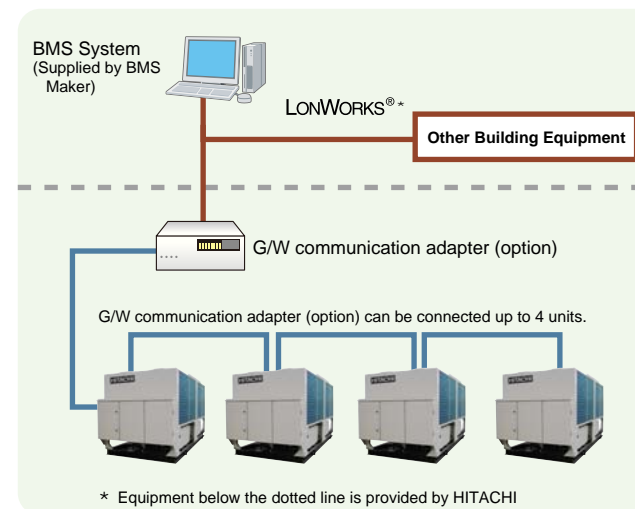

### List of Functions

#### Remote Setting

- ON / OFF Operation
- Chilled Water Temperature (Inlet or Outlet)

#### Remote Monitor

- ON / OFF Status
- Setting Chilled Water Temperature (Inlet or Outlet)
- Current Water Temperature of Inlet and Outlet
- Alarm Code

\* In addition, up to 8 units can be connected using the G/W communication adapter for the Hitachi Chiller Unit signal (RS485).

## Highly Reliable Shell and Tube Heat Exchanger ~ Newly Designed ~

- Dry expansion cooler system
- Low environmental impact: refrigerant quantity reduced by 60% from the current unit
- Perfect matching with the chiller unit due to our own design
  - Downsized by redesigned heat-transfer tube
  - Improved efficiency by optimized refrigerant distribution

# R407C General Data



Model	RCUG75AHYZ1		RCUG100AHYZ1		RCUG120AHYZ1		RCUG150AHYZ1		RCUG180AHYZ1		RCUG200AHYZ1		RCUG240AHYZ1		RCUG270AHYZ1		RCUG300AHYZ1		RCUG330AHYZ1		
Power Source	Main (AC 3 ) 380V / 50Hz, Control (AC 1 ) 220V / 50Hz																				
Nominal Cooling Capacity*1	kW	181	272	340	363	510	544	680	703	726	873										
	USRT	51.6	77.3	96.7	103.2	145.1	154.8	193.4	199.9	206.4	248.2										
	kcal/h	156,019	233,620	292,433	312,038	438,650	468,057	584,867	604,471	624,076	750,688										
Capacity Control	Continuous Capacity Control																				
Outer Dimensions	Width	100~15, 0		100~15(7.5)*2, 0		100~15(5)*2, 0		100~15(7.5)*2, 0		100~15(6)*2, 0		100~15(6)*2, 0									
	Depth	2,390		4,490		4,490		4,490		6,590		6,590		9,080(min.)		9,080(min.)		9,080(min.)		11,180(min.)	
	Height	1,940		1,940		1,940		1,940		1,940		1,940		1,940		1,940		1,940		1,940	
Net Weight	kg	2,057		3,822		4,017		4,103		5,688		5,827		2 x 4,017		4,103 + 4,017		2 x 4,103		5,688 + 4,103	
Refrigerant	Type	R407C																			
	Flow Control	Thermal Expansion Valve																			
	Number of Circuits	1		2		2		3		3		4		4		5		5		5	
Compressor	Type	Semi-Hermetic Screw Type																			
	Model	60ASCC-Z		50ASCC-Z		60ASCC-Z		60ASCC-Z		60ASCC-Z		60ASCC-Z		60ASCC-Z		60ASCC-Z		60ASCC-Z		60ASCC-Z	
	Quantity	1		2		2		3		3		4		4		5		5		5	
Heat Exchanger	Condenser	Cross Fin Type																			
	Condenser Fan	Direct Drive Propeller Fan																			
	Fan Motor Power Output	1.1		1.1		1.1		1.1		1.1		1.1		1.1		1.1		1.1		1.1	
	Quantity	4		8		8		8		12		12		2 x 8		8 + 8		2 x 8		12 + 8	
Evaporator	Shell-and-Tube Type																				
Safety Devices	Overcurrent Relay for Compressor, Internal Thermostat for Compressor, Reverse Phase Protection Device for Compressor, Thermal Overcurrent Relay for Fan Motor, High-Pressure Switch, Low-Pressure Control, Suction Gas Temperature Control, Freeze Protection Thermistor Control, Oil Heater, Discharge Gas Thermistor, Fusible Plug, Fuse for Control Circuit and Pressure Relief Valve																				
Shipping Dimensions	Width	2,600		4,700		4,700		4,700		6,800		6,800		2 x 4,700		2 x 4,700		2 x 4,700		6,800 + 4,700	
	Depth	2,190		2,190		2,190		2,190		2,190		2,190		2,190		2,190		2,190		2,190	
	Height	2,510		2,510		2,510		2,510		2,510		2,510		2,510		2,510		2,510		2,510	
Shipping Weight	kg	2,524		4,442		4,635		4,745		6,813		6,956		2 x 4,635		4,745 + 4,635		2 x 4,745		6,813 + 4,745	
Piping Connections for Water Side Heat Exchanger	Inlet Outlet	With 90 Inner Diameter Companion Flange																			
Connection Hole	Main Power (square orifice)	500 x 200																			
	Circuit	2 x 64.5; 102; 52		3 x 64.5; 102; 52		3 x 64.5; 102; 52		4 x 64.5; 102; 52		4 x 64.5; 102; 52		4 x 64.5; 102; 52		6 x 64.5; 2 x 102; 2 x 52		6 x 64.5; 2 x 102; 2 x 52		7 x 64.5; 2 x 102; 2 x 52		7 x 64.5; 2 x 102; 2 x 52	

Model	RCUG350AHYZ1		RCUG360AHYZ1		RCUG380AHYZ1		RCUG400AHYZ1		
Power Source	Main (AC 3 ) 380V / 50Hz, Control (AC 1 ) 220V / 50Hz								
Nominal Cooling Capacity*1	kW	907	1,020	1,055	1,089				
	USRT	258.0	290.1	299.8	309.6				
	kcal/h	780,095	877,300	906,707	936,113				
Capacity Control	Continuous Capacity Control								
Outer Dimensions	Width	100~15(6)*2, 0		100~15(7.5)*2, 0		100~15(7.5)*2, 0		100~15(7.5)*2, 0	
	Depth	11,180(min.)		13,280(min.)		13,280(min.)		13,280(min.)	
	Height	1,940		1,940		1,940		1,940	
Net Weight	kg	2,170		2,170		2,170		2,170	
Refrigerant	Type	R407C							
	Flow Control	Thermal Expansion Valve							
	Number of Circuits	5		6		6		6	
Compressor	Type	Semi-Hermetic Screw Type							
	Model	60ASCC-Z		60ASCC-Z		60ASCC-Z		60ASCC-Z	
	Quantity	5		6		6		6	
Heat Exchanger	Condenser	Cross Fin Type							
	Condenser Fan	Direct Drive Propeller Fan							
	Fan Motor Power Output	1.1		1.1		1.1		1.1	
	Quantity	12 + 8		2 x 12		12 + 12		2 x 12	
Evaporator	Shell-and-Tube Type								
Safety Devices	Overcurrent Relay for Compressor, Internal Thermostat for Compressor, Reverse Phase Protection Device for Compressor, Thermal Overcurrent Relay for Fan Motor, High-Pressure Switch, Low-Pressure Control, Suction Gas Temperature Control, Freeze Protection Thermistor Control, Oil Heater, Discharge Gas Thermistor, Fusible Plug, Fuse for Control Circuit and Pressure Relief Valve								
Shipping Dimensions	Width	6,800 + 4,700		2 x 6,800		2 x 6,800		2 x 6,800	
	Depth	2,190		2,190		2,190		2,190	
	Height	2,510		2,510		2,510		2,510	
Shipping Weight	kg	6,956 + 4,745		2 x 6,813		6,956 + 6,813		2 x 6,956	
Piping Connections for Water Side Heat Exchanger	Inlet Outlet	With 142 Inner Diameter Companion Flange							
Connection Hole	Main Power (square orifice)	2 x 500 x 200							
	Circuit	7 x 64.5; 2 x 102; 2 x 52		8 x 64.5; 2 x 102; 2 x 52		8 x 64.5; 2 x 102; 2 x 52		8 x 64.5; 2 x 102; 2 x 52	

## NOTES:

- The nominal cooling capacities are based on the following conditions. (\*1)  
Chilled Water Inlet / Outlet Temperature: 12°C / 7°C  
Condenser Air Inlet Temperature: 35°C(DB)
- The units greater than 240AHYZ1 including 240AHYZ1 consist of two modules and are separately shipped.  
The common chilled water piping (Filed-Supplied) between each water cooler shall be directly connected at site.
- Water Flow
  - RCUG240, 300, 360, 400AHYZ1  
It is necessary to control the same water quantity to each cooler.
  - RCUG270, 330, 350, 380AHYZ1  
The chilled water flow rate is different between No.1 & No.2 units.  
It is necessary to control the water quantity of each unit with adjusting valves (Filed-Supplied).
- It is required to connect electrical control wires between No.1 & No.2 units for the unit greater than 240AHYZ1 including 240AHYZ1.
- ( ) marked with \*2 is available by selection switch.

## Working Range

Item	Standard
Chilled Water Outlet Temperature	5~15°C
Condenser Air Inlet Temperature (DB)	5~43°C

Model		RCU75AHYZ1	RCU100AHYZ1	RCU120AHYZ1	RCU150AHYZ1	RCU180AHYZ1	RCU200AHYZ1	RCU240AHYZ1	RCU270AHYZ1	RCU300AHYZ1	RCU330AHYZ1
Power Source		Main (AC 3 ) 380V / 50Hz, Control (AC 1 ) 220V / 50Hz				Main (AC 3 ) 380V / 50Hz, Control (AC 1 ) 220V / 50Hz					
Nominal Cooling Capacity*1	kW	191	286	358	382	537	573	716	740	764	919
	USRT	54.3	81.3	101.8	108.6	152.7	163.0	203.6	210.5	217.3	261.4
	kcal/h	164,230	245,916	307,825	328,461	461,737	492,691	615,649	636,285	656,922	790,198
Capacity Control		Continuous Capacity Control				Continuous Capacity Control					
		100~15, 0		100~15(7.5)*2, 0		100~15(5)*2, 0		100~15(7.5)*2, 0		100~15(6)*2, 0	
Outer Dimensions	Width	2,390	4,490	4,490	4,490	6,590	6,590	9,080(min.)	9,080(min.)	9,080(min.)	11,180(min.)
	Depth	1,940	1,940	1,940	1,940	1,940	1,940	1,940	1,940	1,940	1,940
	Height	2,170	2,170	2,170	2,170	2,170	2,170	2,170	2,170	2,170	2,170
Net Weight	kg	2,057	3,822	4,017	4,103	5,688	5,827	2 x 4,017	4,103 + 4,017	2 x 4,103	5,688 + 4,103
Refrigerant		R22				R22					
Flow Control		Thermal Expansion Valve				Thermal Expansion Valve					
Number of Circuits		1	2		3		4		5		
Compressor		Semi-Hermetic Screw Type				Semi-Hermetic Screw Type					
Type		60ASCC-Z				60ASCC-Z		60ASCC-Z		60ASCC-Z	
Model		50ASCC-Z		60ASCC-Z		60ASCC-Z		60ASCC-Z		60ASCC-Z	
Quantity		1	2		3		4		5		
Heat Exchanger		Cross Fin Type				Cross Fin Type					
Condenser		Direct Drive Propeller Fan				Direct Drive Propeller Fan					
Condenser Fan		Direct Drive Propeller Fan				Direct Drive Propeller Fan					
Fan Motor		Direct Drive Propeller Fan				Direct Drive Propeller Fan					
Power Output		1.1	1.1	1.1	1.1	1.1	1.1	1.1	1.1	1.1	1.1
Quantity		4	8	8	8	12	12	2 x 8	8 + 8	2 x 8	12 + 8
Evaporator		Shell-and-Tube Type				Shell-and-Tube Type					
Safety Devices		Overcurrent Relay for Compressor, Internal Thermostat for Compressor, Reverse Phase Protection Device for Compressor, Thermal Overcurrent Relay for Fan Motor, High-Pressure Switch, Low-Pressure Control, Suction Gas Temperature Control, Freeze Protection Thermistor Control, Oil Heater, Discharge Gas Thermistor, Fusible Plug, Fuse for Control Circuit and Pressure Relief Valve				Overcurrent Relay for Compressor, Internal Thermostat for Compressor, Reverse Phase Protection Device for Compressor, Thermal Overcurrent Relay for Fan Motor, High-Pressure Switch, Low-Pressure Control, Suction Gas Temperature Control, Freeze Protection Thermistor Control, Oil Heater, Discharge Gas Thermistor, Fusible Plug, Fuse for Control Circuit and Pressure Relief Valve					
Shipping Dimensions	Width	2,600	4,700	4,700	4,700	6,800	6,800	2 x 4,700	2 x 4,700	2 x 4,700	6,800 + 4,700
	Depth	2,190	2,190	2,190	2,190	2,190	2,190	2,190	2,190	2,190	2,190
	Height	2,510	2,510	2,510	2,510	2,510	2,510	2,510	2,510	2,510	2,510
Shipping Weight	kg	2,524	4,442	4,635	4,745	6,813	6,956	2 x 4,635	4,745 + 4,635	2 x 4,745	6,813 + 4,745
Piping Connections for Water Side Heat Exchanger		Inlet 90 Inner Diameter Companion Flange		With 142 Inner Diameter Companion Flange		With 142 Inner Diameter Companion Flange					
Outlet		90 Inner Diameter Companion Flange		142 Inner Diameter Companion Flange		142 Inner Diameter Companion Flange					
Connection Hole		500 x 200				500 x 200		2 x 500 x 200			
Main Power (square orifice)		2 x 64.5; 102; 52		3 x 64.5; 102; 52		4 x 64.5; 102; 52		6 x 64.5; 2 x 102; 2 x 52		7 x 64.5; 2 x 102; 2 x 52	
Circuit		2 x 64.5; 102; 52		3 x 64.5; 102; 52		4 x 64.5; 102; 52		6 x 64.5; 2 x 102; 2 x 52		7 x 64.5; 2 x 102; 2 x 52	

Model		RCU350AHYZ1	RCU360AHYZ1	RCU380AHYZ1	RCU400AHYZ1
Power Source		Main (AC 3 ) 380V / 50Hz, Control (AC 1 ) 220V / 50Hz			
Nominal Cooling Capacity*1	kW	955	1,074	1,110	1,146
	USRT	271.6	305.5	315.7	325.9
	kcal/h	821,152	923,474	954,428	985,383
Capacity Control		Continuous Capacity Control			
		100~15(6)*2, 0		100~15(7.5)*2, 0	
Outer Dimensions	Width	11,180(min.)	13,280(min.)	13,280(min.)	13,280(min.)
	Depth	1,940	1,940	1,940	1,940
	Height	2,170	2,170	2,170	2,170
Net Weight	kg	5,827 + 4,103	2 x 5,688	5,827 + 5,688	2 x 5,827
Refrigerant		R22			
Flow Control		Thermal Expansion Valve			
Number of Circuits		5	6		6
Compressor		Semi-Hermetic Screw Type			
Type		60ASCC-Z			
Model		60ASCC-Z		60ASCC-Z	
Quantity		5	6		6
Heat Exchanger		Cross Fin Type			
Condenser		Direct Drive Propeller Fan			
Condenser Fan		Direct Drive Propeller Fan			
Fan Motor		Direct Drive Propeller Fan			
Power Output		1.1	1.1	1.1	1.1
Quantity		12 + 8	2 x 12	12 + 12	2 x 12
Evaporator		Shell-and-Tube Type			
Safety Devices		Overcurrent Relay for Compressor, Internal Thermostat for Compressor, Reverse Phase Protection Device for Compressor, Thermal Overcurrent Relay for Fan Motor, High-Pressure Switch, Low-Pressure Control, Suction Gas Temperature Control, Freeze Protection Thermistor Control, Oil Heater, Discharge Gas Thermistor, Fusible Plug, Fuse for Control Circuit and Pressure Relief Valve			
Shipping Dimensions	Width	6,800 + 4,700	2 x 6,800	2 x 6,800	2 x 6,800
	Depth	2,190	2,190	2,190	2,190
	Height	2,510	2,510	2,510	2,510
Shipping Weight	kg	6,956 + 4,745	2 x 6,813	6,956 + 6,813	2 x 6,956
Piping Connections for Water Side Heat Exchanger		Inlet 142 Inner Diameter Companion Flange			
Outlet		142 Inner Diameter Companion Flange			
Connection Hole		2 x 500 x 200			
Main Power (square orifice)		7 x 64.5; 2 x 102; 2 x 52		8 x 64.5; 2 x 102; 2 x 52	
Circuit		7 x 64.5; 2 x 102; 2 x 52		8 x 64.5; 2 x 102; 2 x 52	

**NOTES:**

- The nominal cooling capacities are based on the following conditions. (\*1)  
Chilled Water Inlet / Outlet Temperature: 12°C / 7°C  
Condenser Air Inlet Temperature: 35°C(DB)
- The units greater than 240AHYZ1 including 240AHYZ1 consist of two modules and are separately shipped.  
The common chilled water piping (Filed-Supplied) between each water cooler shall be directly connected at site.
- Water Flow
  - RCU240, 300, 360, 400AHYZ1  
It is necessary to control the same water quantity to each cooler.
  - RCU270, 330, 350, 380AHYZ1  
The chilled water flow rate is different between No.1 & No.2 units.  
It is necessary to control the water quantity of each unit with adjusting valves (Filed-Supplied).
- It is required to connect electrical control wires between No.1 & No.2 units for the unit greater than 240AHYZ1 including 240AHYZ1.
- ( ) marked with \*2 is available by selection switch.

**Working Range**

Item	Standard
Chilled Water Outlet Temperature	5~15°C
Condenser Air Inlet Temperature (DB)	5~43°C

# Dimensional Data

## R407C RCUG75AHYZ1

### R22 RCU75AHYZ1

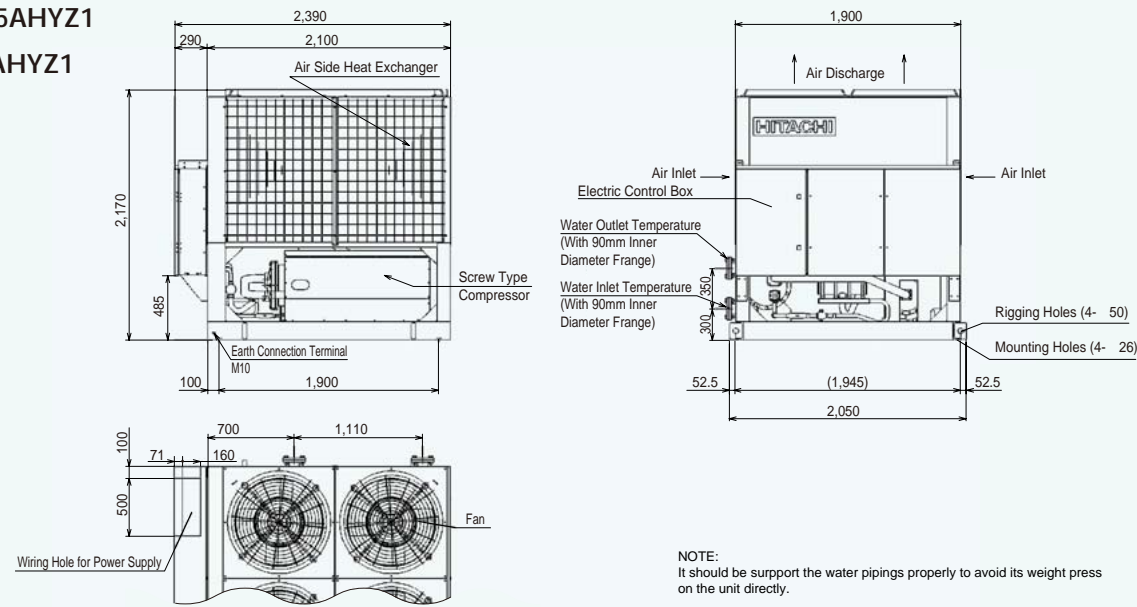

NOTE:  
It should be support the water pipings properly to avoid its weight press on the unit directly.

## R407C RCUG240, 270 and 300AHYZ1

### R22 RCU240, 270 and 300AHYZ1

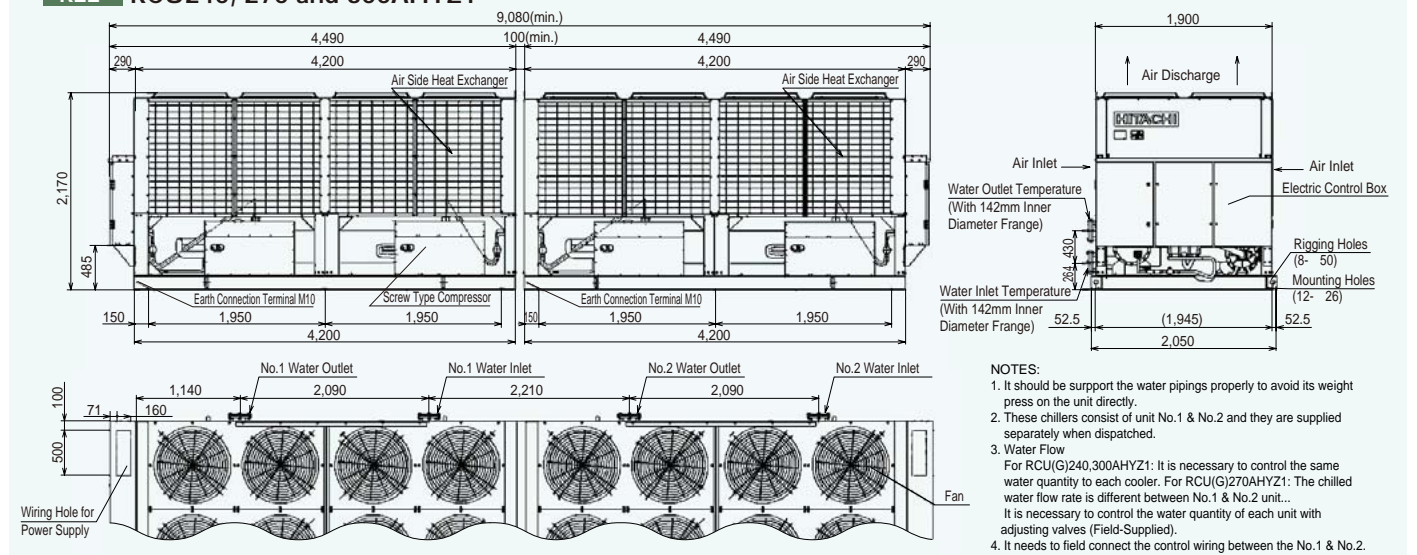

NOTES:  
1. It should be support the water pipings properly to avoid its weight press on the unit directly.  
2. These chillers consist of unit No.1 & No.2 and they are supplied separately when dispatched.  
3. Water Flow  
For RCU(G)240,300AHYZ1: It is necessary to control the same water quantity to each cooler. For RCU(G)270AHYZ1: The chilled water flow rate is different between No.1 & No.2 unit... It is necessary to control the water quantity of each unit with adjusting valves (Field-Supplied).  
4. It needs to field connect the control wiring between the No.1 & No.2.

## R407C RCUG100, 120 and 150AHYZ1

### R22 RCU100, 120 and 150AHYZ1

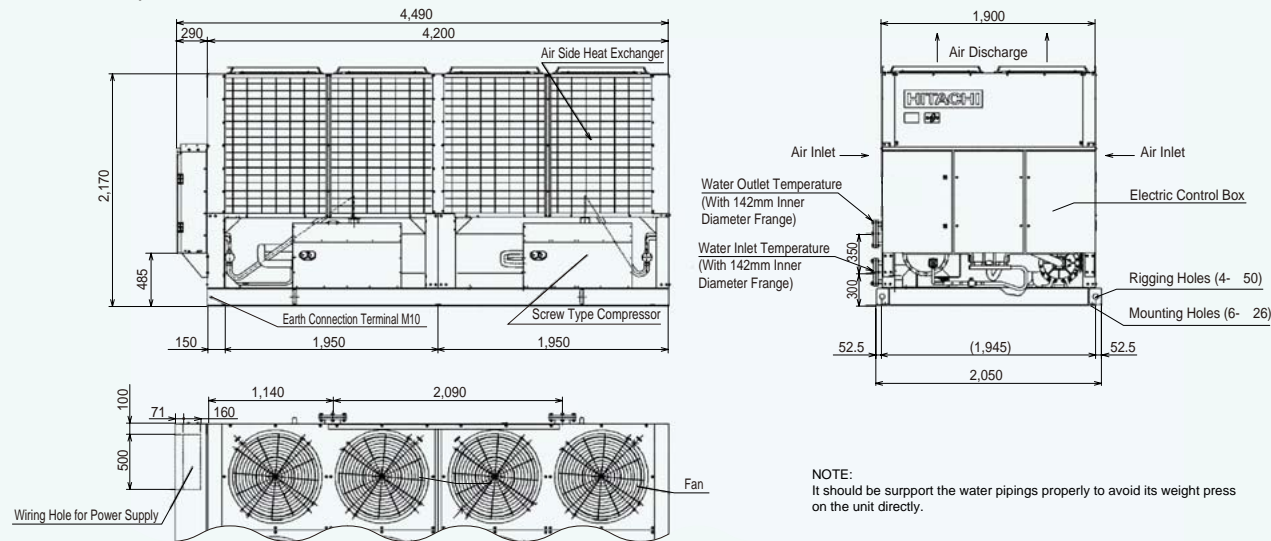

NOTE:  
It should be support the water pipings properly to avoid its weight press on the unit directly.

## R407C RCUG330 and 350AHYZ1

### R22 RCU330 and 350AHYZ1

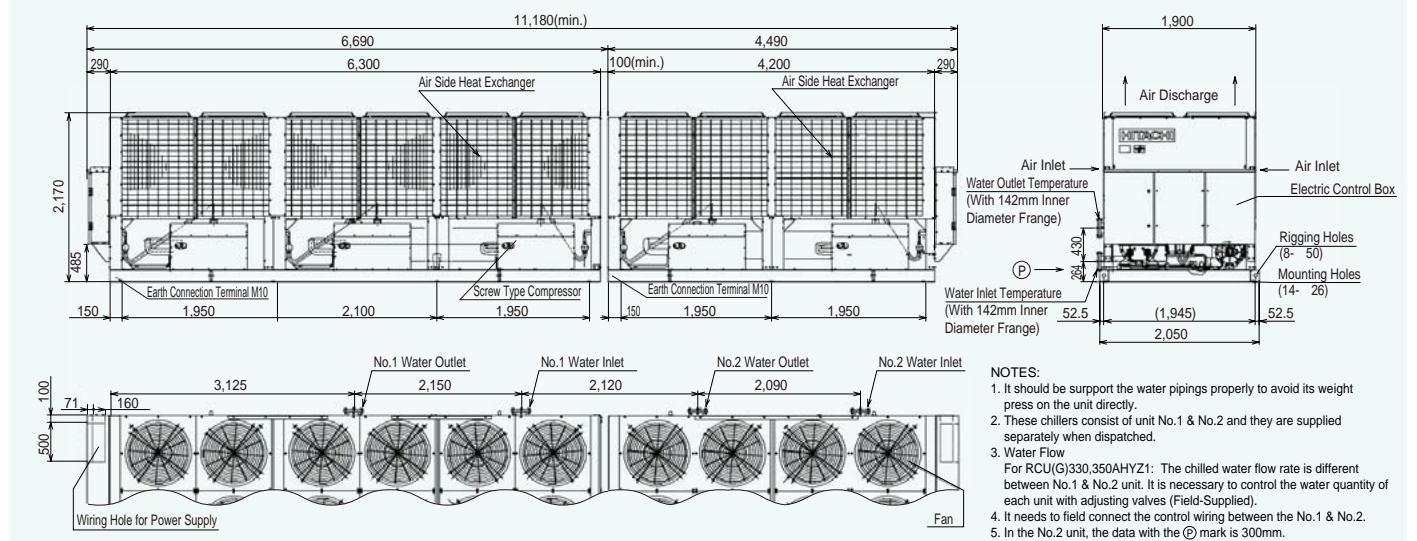

NOTES:  
1. It should be support the water pipings properly to avoid its weight press on the unit directly.  
2. These chillers consist of unit No.1 & No.2 and they are supplied separately when dispatched.  
3. Water Flow  
For RCU(G)330,350AHYZ1: The chilled water flow rate is different between No.1 & No.2 unit. It is necessary to control the water quantity of each unit with adjusting valves (Field-Supplied).  
4. It needs to field connect the control wiring between the No.1 & No.2.  
5. In the No.2 unit, the data with the (P) mark is 300mm.

## R407C RCUG180 and 200AHYZ1

### R22 RCU180 and 200AHYZ1

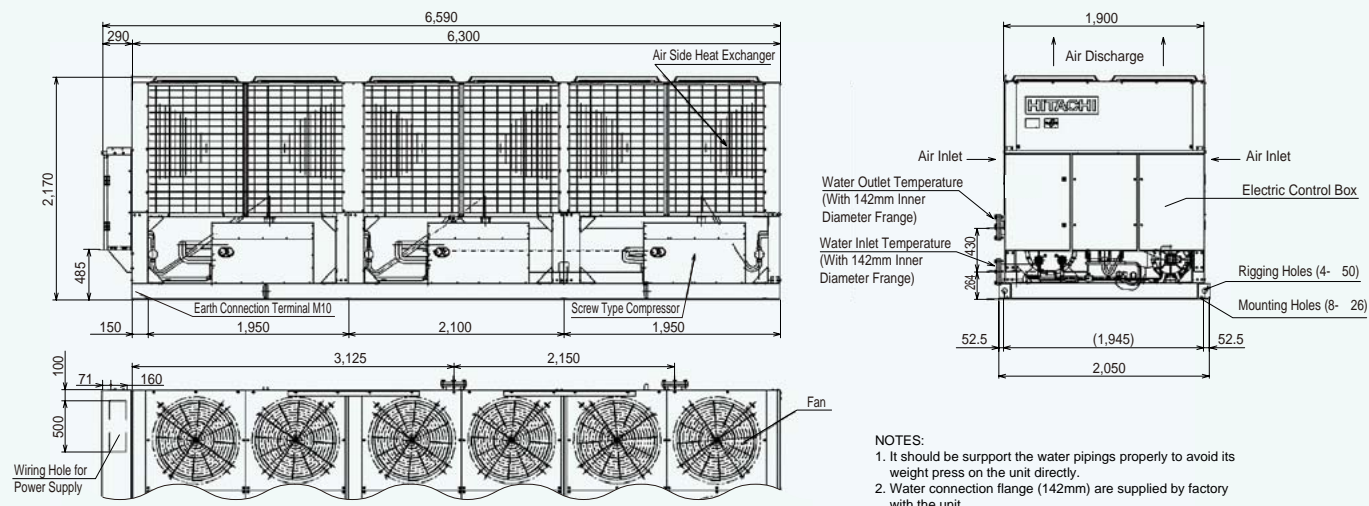

NOTES:  
1. It should be support the water pipings properly to avoid its weight press on the unit directly.  
2. Water connection flange (142mm) are supplied by factory with the unit.

## R407C RCUG360, 380 and 400AHYZ1

### R22 RCU360, 380 and 400AHYZ1

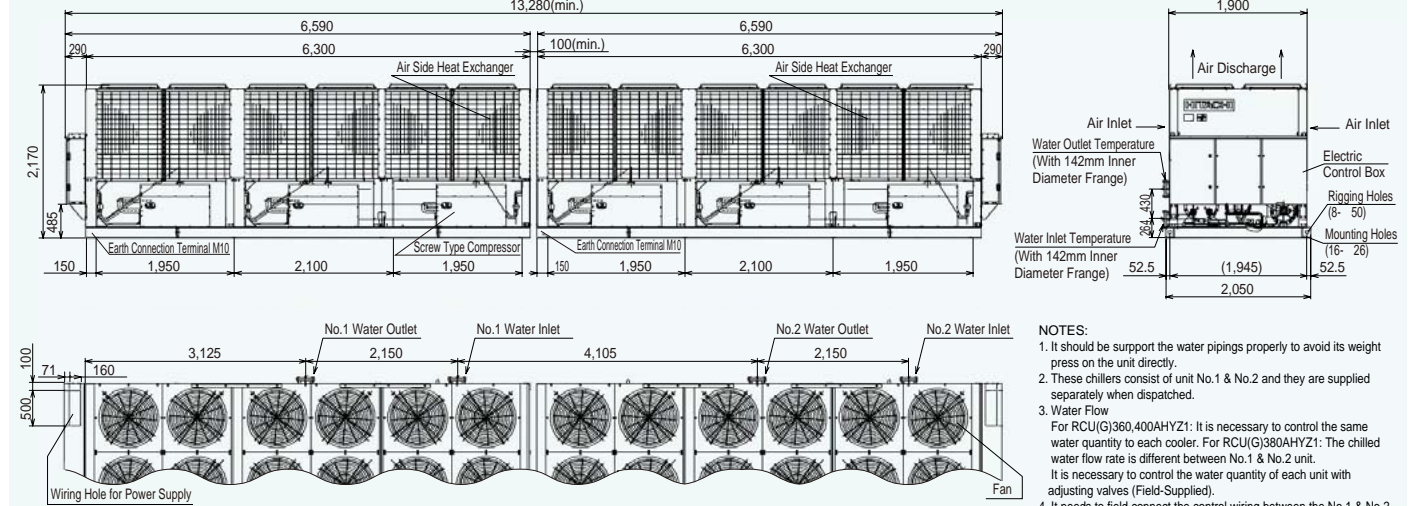

NOTES:  
1. It should be support the water pipings properly to avoid its weight press on the unit directly.  
2. These chillers consist of unit No.1 & No.2 and they are supplied separately when dispatched.  
3. Water Flow  
For RCU(G)360,400AHYZ1: It is necessary to control the same water quantity to each cooler. For RCU(G)380AHYZ1: The chilled water flow rate is different between No.1 & No.2 unit. It is necessary to control the water quantity of each unit with adjusting valves (Field-Supplied).  
4. It needs to field connect the control wiring between the No.1 & No.2.